



# OPERATOR MANUAL

**TX25H**

# **OPERATOR'S MANUAL**

## **Summit TX25 Hydrostatic Tractor**

**Summit Tractors LLC  
3379 Peachtree Road NE Suite 555  
Atlanta GA 30326**

## Welcome to the Summit Tractor's Family

Dear Summit Tractor Owner,

On behalf of the entire Summit Tractors team, we thank you for the confidence that you have in the **Summit Tractors™** brand and our products, the retail store where you made your purchase, and our family of U.S. and international tractor, attachments, tires & wheels, and accessories manufacturing partners.

We realize that you have many choices when it comes to purchasing compact utility tractor equipment, and we endeavor to exceed your expectations for the overall value, quality and productivity of the equipment, and through our customer and equipment service network.

If you haven't already done so, we invite you to download the **Summit Tractors Connect™** iOS or Android app, where you will find an abundance of resources, all designed to help you and your family get the most out of your tractor, properly maintain it, and to help fulfill your dreams for the family homestead.

Before using your tractor, we highly recommend that you and any other person that will use your tractor read this operator's manual thoroughly, with a particular focus on the **SAFETY** related information covered in **Chapter 2, WARRANTY & SAFETY**.

To properly maintain your equipment, you will find very useful information related to routine checks and periodic maintenance in **Chapter 5, MAINTENANCE**. If you want to perform your own periodic maintenance, we will assist by providing access to the right parts and procedures as found through the Summit Tractors Connect™ app. If you'd like to have one of our Summit Tractors Service Partners handle tractor maintenance for you, use the app to find the service location nearest you.

Again, we thank you, and welcome you to the family of Summit Tractors™ owners. We will always do our best to support you throughout many years of productive and trouble-free use of your equipment.

Sincerely,

*Doug Rehor*

Doug Rehor  
Founder & CEO

*Daniel Patterson*

Daniel Patterson  
Chief Operating Officer

This publication has been written in compliance with International Standard ISO 3600 'Guide for information, contents and presentation of operation and maintenance manuals supplied with tractors and machinery for agricultural and forestry use.





## TABLE OF CONTENTS

DESCRIPTION	PAGE NO.
<b>CHAPTER 1: INTRODUCTION &amp; IDENTIFICATION</b>	
Using This Operator Manual .....	10-7
Chassis Serial Number .....	10-8
Engine Serial Number .....	10-8
Statutory Plate.....	10-8
ROPS Certificate Plate.....	10-8
Universal Symbols .....	10-9
<b>CHAPTER 2: WARRANTY &amp; SAFETY</b>	
Warranty Guidelines.....	20-1-4
Guidelines about Safety Sign.....	20-5
Safety Labels.....	20-5
Safety Labels Location.....	20-6-10
Safety: Prepare For Safe Operation.....	20-11
Safety Notes.....	20-12-25
Safety While Operating Loader Attachments.....	20-24
Safety From Lightning Strike.....	20-25
Noise & Vibration Levels.....	20-26
<b>CHAPTER 3: INSTRUMENTS &amp; CONTROLS</b>	
Tractor Controls .....	30-1
Instrument Panel .....	30-2
Parking Brake Indicator.....	30-3
Battery Charge Indicator .....	30-3
Air Cleaner Clogging Indicator .....	30-3
Left Turn Indicator .....	30-3
Right Turn Indicator.....	30-4
High Beam Indicator.....	30-4
Cold Start Indication.....	30-4
Engine Oil Pressure Indicator .....	30-5
Temperature Gauge .....	30-5
PTO Monitor Lamp.....	30-6
Trailer Turn Indicator .....	30-6
Engine RPM (Revolution Per Minute) Meter and Hour Meter .....	30-6
Work Lamp Indicator .....	30-7
Fuel Gauge .....	30-7
Cruise Control .....	30-7
Dashboard Controls .....	30-8
PTO On/Off Switch .....	30-10
Cruise Control Switch.....	30-10
Fuse Box.....	30-10
Tractor Lights.....	30-11
Operator's Seat.....	30-12
Battery.....	30-13
Seven Pin Socket.....	30-13
<b>CHAPTER 4: OPERATION</b>	
Operator Presence Control (OPC).....	40-1
Boarding the Tractor.....	40-1

## TABLE OF CONTENTS

DESCRIPTION	PAGE NO.
Leaving the Tractor .....	40-1
Engine .....	40-1
Starting the Engine .....	40-1
Breaking in .....	40-3
Turning off the Engine .....	40-3
Under Hood Muffler .....	40-4
Opening and closing the Hood .....	40-4
Speed Control Pedal .....	40-4
Cruise Control .....	40-5
2WD / 4WD' Lever .....	40-5
Hand Throttle Lever .....	40-6
Differential Lock .....	40-6
PTO ON-OFF Switch .....	40-6
PTO .....	40-7
Hydraulic Coupling Devices .....	40-10
Power Steering .....	40-10
Transport Lock (Response Valve) .....	40-10
Hi-Low Lever .....	40-11
Service Brakes .....	40-11
Parking Brake .....	40-11
Gear Speed Chart .....	40-12
Wheels and Tires (Tire Inflation Pressure & Load Carrying Capacity) .....	40-12
Check Wheel Nut Bolt, Tread Settings .....	40-12
Three Point Linkage .....	40-14
Roll Over Protection Structure (ROPS) .....	40-16
<b>CHAPTER 5: MAINTENANCE</b>	
Maintenance Schedule .....	50-1
Fuel Tank Filling .....	50-3
Replacement of Fuel Filter .....	50-4
Air Bleeding of Fuel System .....	50-4
Radiator .....	50-4
Checking Coolant Level in Radiator .....	50-4
Checking Engine Oil Level .....	50-5
Replacement of Oil Filter & Engine Oil .....	50-5
Radiator Draining & Flushing (When cold) .....	50-6
Radiator Fins Cleaning .....	50-6
Radiator Cap .....	50-6
Inspection of Hoses .....	50-6
Air Cleaner Maintenance .....	50-7
Foot Brake Pedals .....	50-8
Steering Cylinder Knuckle Joints .....	50-8
Oil Changes in 4WD Front Axle .....	50-8
Transmission and Hydraulic Oil Change .....	50-8
Transmission Oil grades .....	50-9
Hydraulic Filter Replacement .....	50-10

## TABLE OF CONTENTS

<b>DESCRIPTION</b>	<b>PAGE NO.</b>
Cleaning of Suction Strainer .....	50-11
General Maintenance of Electrical System .....	50-12
Battery and its Maintenance .....	50-13
Fuses in Fuse Box .....	50-13
Long Storage Period .....	50-13
Starter Motor .....	50-14
Alternator.....	50-14
Checking V-belt.....	50-14
Adjusting V-belt tension .....	50-14
Greasing Points.....	50-15
Jack Up the Tractor - Lifting Points .....	50-16
Oil and Lubrication Chart .....	50-16
<b>CHAPTER 6: TECHNICAL SPECIFICATIONS</b>	
Technical Specifications .....	60-1
<b>CHAPTER 7: DO'S AND DON'TS</b>	
Do's & Don'ts.....	70-1-3
<b>CHAPTER 8: TROUBLESHOOTING, SERVICE RECORD &amp; ALPHABETICAL INDEX</b>	
Troubleshooting.....	80-1-2
Service Record.....	80-3
Alphabetical Index.....	80-4

# INTRODUCTION & IDENTIFICATION

## Using This Operator Manual

This manual is an important part of your tractor and it should be kept with the tractor at all times.

Reading this manual will help you and others avoid personal injury or damage to the tractor. Information provided in this manual will help you to use the tractor in safest and effective way.

If you have an attachment, use the safety and operating information in the attachment operator's manual along with the tractor operator's manual to operate the attachment safely and correctly.

The tractor shown in this manual may differ slightly from your tractor, but will be similar enough to help you understand our instructions.

Throughout this manual, the use of terms left side, right side, front side and rear side must be understood, to avoid any confusion when following these instructions. The left and right means left and right sides of the tractor when facing in the direction of forward travel, reference to the front indicates the radiator end of the tractor, while the rear, indicates the draw bar end.

Always specify the tractor chassis and engine serial numbers when you need replacement parts. This will facilitate correct & faster delivery of required parts from the authorized servicing dealer. For easy reference, we suggest you to record these numbers in the space provided in the 'ownership and tractor details' page before this chapter.

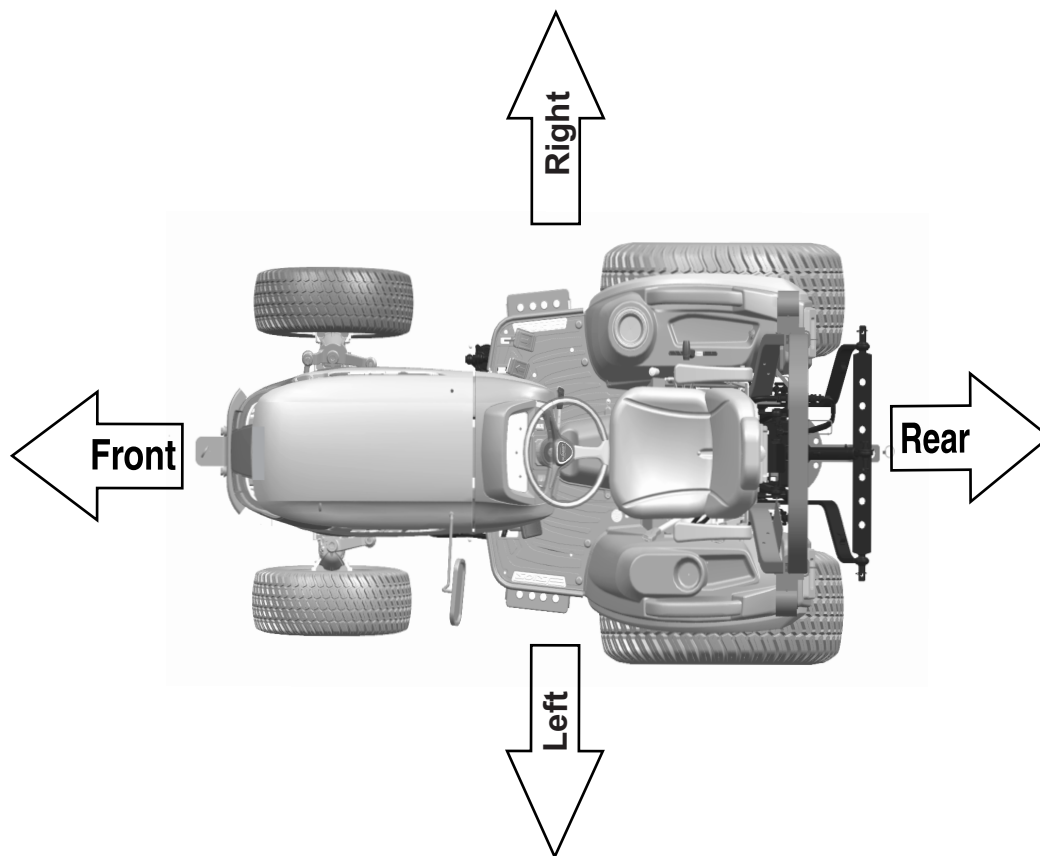

# INTRODUCTION & IDENTIFICATION

## SUMMIT TX25

**Chassis Serial Number (A):** Chassis number is punched on right side of front axle bracket of the tractor (see fig. A). Should you find the number difficult to read, you will also find it on the statutory plate.

**Engine Serial Number (B):** The engine serial number is stamped on the upper side of the fuel injection pump installation part located in the right side of cylinder block. For easy reference, engine serial number is also mentioned on valve cover of the engine (see fig. B).

**Statutory Plate (C):** Chassis number is also engraved on statutory plate. Statutory plate is located on left hand side fender (fig. C).

**ROPS Certificate Plate (D) - Optional:** ROPS certificate plate is riveted on ROPS. Information about ROPS serial number and tractor model is engraved on ROPS plate. For countries under EEC, ROPS certificate plate is used as shown in fig. D.

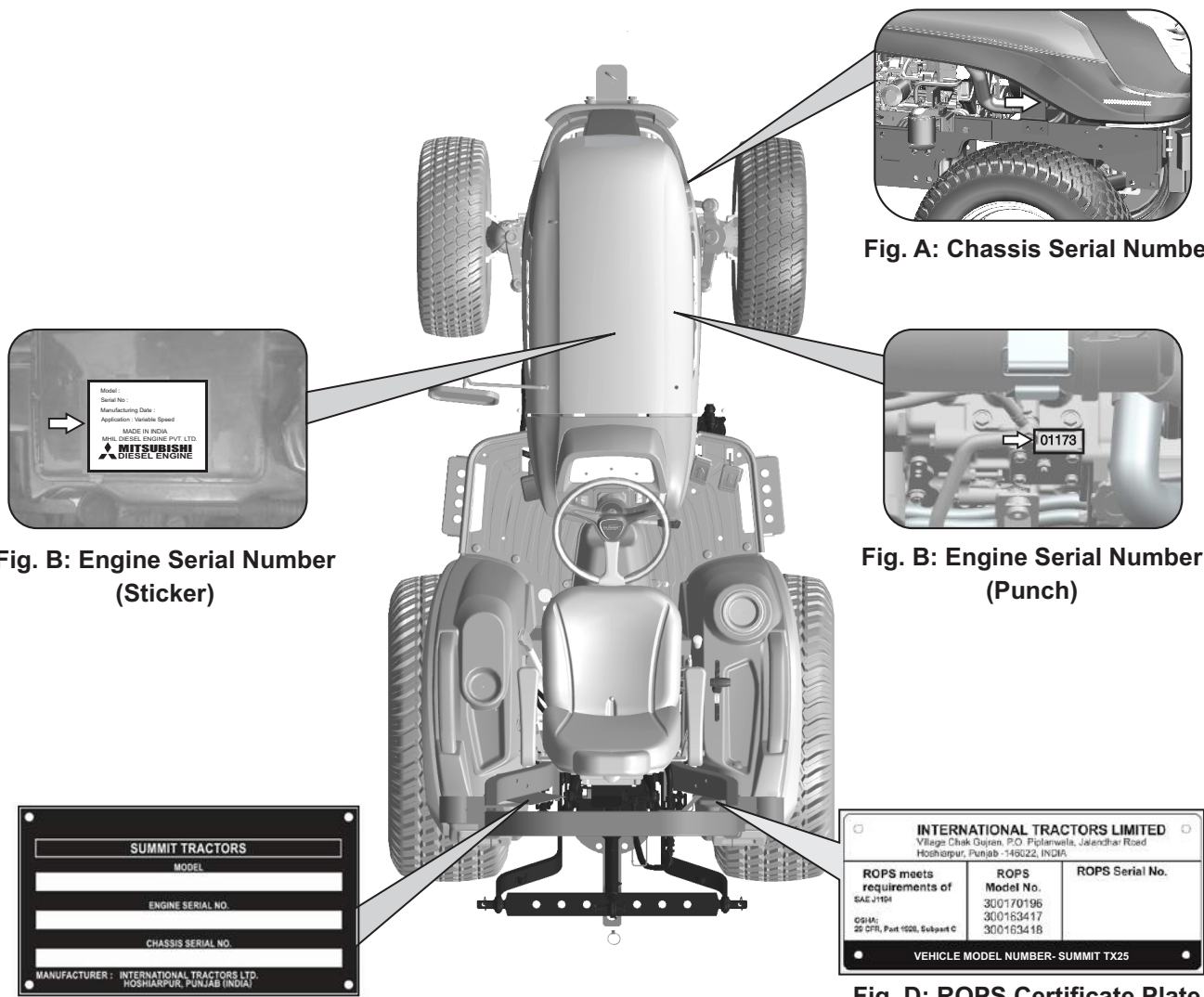

**Fig. A: Chassis Serial Number**

**Fig. B: Engine Serial Number (Sticker)**

**Fig. B: Engine Serial Number (Punch)**





























**Fig. C: Statutory Plate**

**Fig. D: ROPS Certificate Plate**

# INTRODUCTION & IDENTIFICATION

## Universal Symbols

As a guide to the operation of your tractor, various universal symbols have been utilized on the instruments, controls and other places on tractor. The symbols are shown below with an indication of their meaning.

	Read Operator's Manual		Fast
	Safety Alert Symbol		Slow
	Fuel Level		Engine Coolant-Temperature
	Engine Rotational Speed n/min		PTO 540
	Parking Brake		Differential Lock
	Air Cleaner Clogging Sensor		Hydraulic Control-Lowered Position
	Battery Charging Condition		Hydraulic Control-Raised Position
	Engine Oil-Pressure		Engine Speed Control
	Turn Signal		Remote Cylinder-Retract
	Power Take-Off Clutch Control-Off Position		Remote Cylinder-Extend
	Power Take-Off Clutch Control-On Position		Engine Stop
	Hazard Warning Lights		
	Master Lighting Switch		
	Parking Brake Indication		
	Headlight-Low Beam		
	Headlight-High Beam		
	Audible Warning Device		
	Four-Wheel Drive-On		
	Four-Wheel Drive-Off		

# WARRANTY

## Limited Warranty for New Summit Tractors

### General Provisions

The warranties described below are provided by Summit Tractors LLC (“Summit”) to the original purchases of new SUMMIT brand tractors (“Equipment”) from any SUMMIT retailer store location. Under the warranties provided by SUMMIT, SUMMIT will repair or replace, at its option, any covered part which is found to be defective in material or workmanship during the applicable warranty term. Warranty service must be performed at a service center authorized by SUMMIT to service the type of Equipment involved, which will use only new or re-manufactured parts or components furnished or sourced by SUMMIT. Warranty service will be performed without charge to the purchaser for parts and labor. The purchaser will be responsible, however, for any service call and/or transportation of any Equipment or Product to and from the service center’s place of business, and for any service and/or maintenance not directly related to any defect covered under the warranties below. These warranties are transferable provided an authorized SUMMIT service center is notified of the ownership change, and SUMMIT approves the transfer in writing.

### What is Warranted?

Subject to the Length of Warranty Chart provided in the document “LIMITED WARRANTY FOR NEW SUMMIT TRACTORS” warranty statement provided at time of purchase and available for review and download at [www.summittractors.com](http://www.summittractors.com), as amended from time to time, acknowledging limitations on the term of warranty, all parts of any new SUMMIT Equipment, except tires, wheels, starter motor, battery and alternator (which are warranted under separate documents provided with each product), are warranted for the number of months or operating hours specified. Warranty statements required by law covering engine emission-related parts and components, which shall not be less than the engine warranty, are found in the operator’s manual delivered with the equipment,

specifically on the pages that follow. Included in the Summit Tractors Powertrain Warranty - Engine: cylinder block, cylinder head, valve covers, oil pan, timing gear covers, flywheel housing, emission control components and all parts contained therein. Powertrain: Transmission, transmission case, differential and axle housing, MFWD front axle assembly, and all parts contained therein. The Powertrain Warranty does not include external drivelines, or steering cylinders including but not limited to the HST assembly (HST pump), HST damper plate, and the HST damper assembly.

### What is Not Warranted?

SUMMIT IS NOT RESPONSIBLE FOR THE FOLLOWING: (1) Used equipment; (2) Any Equipment that has been altered or modified in ways not approved by SUMMIT, including but not limited to setting injection pump fuel delivery above SUMMIT or manufacturer specifications; (3) Depreciation or damage caused by normal wear and tear, lack of reasonable or proper maintenance, failure to follow operating instructions, misuse, lack of proper protection during storage, or accident; (4) Normal maintenance parts and service including, but not limited to, light bulbs, filters (oil, fuel, air and hydraulic), belts, motor brushes, brakes, fuses and switches, clutch linings, engine tune-up, wheel alignment, blade sharpening and lubrication. Purchasers have a duty to maintain maintenance records. In SUMMIT’s sole and absolute discretion, SUMMIT may request documentation of maintenance. Failure to maintain and provide maintenance records upon request, at the option of SUMMIT, shall void all warranty and prohibit all warranty claims.

# WARRANTY

## Securing Warranty Service

To secure warranty service, the original purchaser or a subsequent purchaser to whom the applicable warranty has been properly transferred as described above must (1) Report the product defect in writing to an authorized Summit Tractors service center and request repair within the applicable warranty period (2) Present written evidence that the warranty registration for the particular piece of Equipment has been completed and indicate the warranty start date, and (3) Bring the Equipment to an [authorized] SUMMIT service center within five (5) business days and prior to the expiration of the applicable warranty period.

## Limitation of Implied Warranties and other Remedies - Equipment

To the extent permitted by law, neither SUMMIT nor any business entity affiliated with SUMMIT (“SUMMIT Affiliate”), nor any director, officer, employee, or member of SUMMIT or any SUMMIT Affiliate, make(s) any warranties, representations or promises as to the quality, performance or freedom from defect of the Equipment covered by the warranties described herein. Except as described in this Limited Warranty, no other warranty is provided and ALL OTHER WARRANTIES ARE DISCLAIMED, INCLUDING BUT NOT LIMITED TO ALL EXPRESS AND IMPLIED WARRANTIES, WARRANTY OF MERCHANTABILITY AND FITNESS FOR A PARTICULAR PURPOSE. All existing warranties, including IMPLIED WARRANTIES OF MERCHANTABILITY AND FITNESS FOR A PARTICULAR PURPOSE, TO THE EXTENT APPLICABLE, SHALL BE LIMITED IN DURATION TO THE APPLICABLE PERIOD OF WARRANTY SET FORTH HEREIN. Unless otherwise prohibited by law, THE PURCHASER’S ONLY REMEDIES IN CONNECTION WITH THE BREACH OR PERFORMANCE OF ANY WARRANTY OF THE EQUIPMENT ARE THOSE SET FORTH HEREIN. IN NO EVENT WILL THE SERVICE CENTER, SUMMIT OR ANY SUMMIT AFFILIATE OR AGENT THEREOF BE LIABLE FOR INCIDENTAL OR CONSEQUENTIAL DAMAGES (INCLUDING BUT NOT LIMITED TO, LOSS OF REVENUE, LOSS OF USE, LOAN PAYMENTS, COST OF RENTAL OR SUBSTITUTE EQUIPMENT, INSURANCE COVERAGE, STORAGE, LODGING, TRANSPORTATION, FUEL, MILEAGE AND COMMUNICATION COSTS). (Note: some states do not allow limitations on how long and implied warranty lasts or the exclusion or limitation of incidental or consequential damages so the above limitations and exclusions may not apply to you, but they are intended to apply to the greatest extent permitted by law.) This warranty gives you the specific legal rights, and you may

also have other rights which vary from state to state. NEITHER SERVICE DEALER, NOR ANY OF ITS EMPLOYEES, AGENTS, OR REPRESENTATIVES ARE AUTHORIZED TO PROVIDE ANY ORAL WARRANTY, OR ASSUME AND ADDITIONAL OBLIGATIONS OR LIABILITIES IN CONNECTION WITH SALE OR RESALE OF THE PRODUCTS. ANY ORAL STATEMENT MADE BY SERVICE DEALER OR ANY OF ITS EMPLOYEES, AGENTS OR REPRESENTATIVES REGARDING THE PRODUCTS DO NOT CONSTITUTE WARRANTIES, MAY NOT BE RELIED UPON AS SUCH BY THE PURCHASER AND ARE NOT PART OF ANY WARRANTY.

If further information is needed from Summit Tractors please refer to [www.Summittractors.com](http://www.Summittractors.com) or the Summit Connect APP.



# WARRANTY

## Emission System Warranty Statement

Summit warrants to the purchaser that at the time of initial sale, the engine used in the Summit brand tractor is designed, built and equipped to conform to all applicable regulations of US Environmental Protection Agency (EPA), and that the engine is free of defects in materials and workmanship that may cause this engine to fail to conform with EPA regulations during its warranty period.

### Coverage - Emission Warranty

The emission system warranty equals the duration of the tractor's limited powertrain warranty as outlined in the "LIMITED WARRANTY FOR NEW SUMMIT TRACTORS" warranty statement provided at time of purchase and available for review and download at [www.summittractors.com](http://www.summittractors.com)

### General Provisions

A. The warranty period begins on the date the product is delivered to the purchaser.

B. General emissions warranty coverage – Summit warrants to the purchaser that each engine is:

I. Designed, built, and equipped so as to conform all applicable regulations adopted by US EPA.

II. Free from defects in materials and workmanship that cause the failure of warranted part during the warranty period.

III. This warranty may be transferable to each subsequent purchaser for the for the duration of warranty period.

IV. Summit requires that repair or replacement of any warranted part be performed at an authorized Summit Tractors Service Dealer location.

C. The warranty on emissions-related parts will be interpreted as follows:

I. Any warranted part not included for periodic replacement as part of scheduled maintenance that fails during the period of warranty coverage will be repaired or replaced by the manufacturer according to subsection (iv) below. Any such part repaired or replaced under warranty will be warranted for the

remaining warranty period.

II. Any warranted part that is scheduled only for regular inspection in the written instructions required by subsection (B) must be warranted for the warranty period. A statement in such written instructions to the effect of "repair or replace as necessary" will not reduce the period of warranty coverage. Any such part repaired or replaced under warranty must be warranted for the remaining warranty period.

III. Any warranted part that is scheduled for replacement as required maintenance in the written instructions required by subsection (B) must be warranted for the period of time prior to first scheduled replacement point for that part. If the part fails prior to first scheduled replacement, the part shall be repaired or replaced by Summit according to subsection (iv) below. Any such part repaired or replaced under warranty must be warranted for remainder of period prior to first scheduled replacement point for the part.

IV. Repair or replacement of any warranted part under the warranty must be performed at no charge to the owner at an authorized Summit Tractors Service Dealer location.

V. The purchaser shall not be charged for diagnostic labor that leads to the determination that a warranted part is in fact defective, provided that such diagnostic work is performed at an authorized Summit Tractors Service Dealer location.

VI. Summit is liable for damage to other engine components in proximity caused by a failure of any warranted part.

VII. Summit's manufacturing partner ITL shall maintain a supply of warranted parts sufficient to meet the expected demand of such parts.

VIII. Any replacement part may be used in the performance of any warranty maintenance or repairs and shall be provided without charge to the purchaser. Such use will not reduce the warranty obligations.

# WARRANTY

IX. Add-on or modified parts that are not exempted by the California Air Resources Board (CARB) and EPA shall not be used. The use of any non-exempted add-on or modified parts will be grounds for disallowing a warranty claim. Summit will not be liable to warrant failures of warranted parts caused by the use of a non-exempted add-on or modified part.

X. If requested by the EPA, Summit shall provide any documents that describe that Summit's warranty procedures or policies within 15 (fifteen) working days of request.

- Abuse, neglect, improper maintenance or unapproved modifications or alterations
- Accidents for which Summit has no responsibility or acts of God
- Use of fuel not recommended by Summit

## D. Emission Warranty Parts List

### I. Air Induction System

- Intake manifold

### II. Thermal Reactor System

- Exhaust manifold

### III. Fuel Injection System

- Fuel supply pump
- Injector
- Injection pipe
- Cold advance timer
- Fuel injection pump
- Any device used to collect particulate emissions
- Control device enclosures and manifolds

### IV. Miscellaneous Items

- Closed breather system
- Hoses\*, clamps\*, fittings\*, tubing\*
- Gaskets, seals
- Engine manufacturer supplied wiring harnesses
- Engine manufacturer supplied electrical connectors
- Air cleaner element\*
- Fuel filter element\*
- Emission control information labels

**\*Until the first scheduled replacement point**

## E. Emission Warranty Exclusions

Summit may deny warranty claims for malfunctions or failures caused by:

- Non-performance of scheduled maintenance
- The use of the engine/tractor in a manner for which it is not designed

# SAFETY NOTES

This safety alert symbol means **ATTENTION!**  
**BECOME ALERT! YOUR SAFETY IS INVOLVED!**



The safety alert symbol identifies important safety messages on machines, safety signs, in manuals or elsewhere. When you see this symbol, be alert to the possibility of personal injury or death.

Why is **SAFETY** important to you?

**\* ACCIDENTS are COSTLY \* \* ACCIDENTS can be AVOIDED\***

## Guidelines About Safety Sign

### Recognize Safety Information:

Any of the following symbols on your machine or in this manual, alert you to the potential for personal injury. Follow recommended precautions and safe operating practices.



**DANGER**

The symbol and the word **DANGER** indicate an immediate hazardous situation, which if not avoided, can result in **DEATH OR VERY SERIOUS INJURY**.



**WARNING**

The symbol and the word **WARNING** indicate a potentially hazardous situation. If the instructions or procedures are not correctly followed it could result in **DEATH OR VERY SERIOUS INJURY**.



**CAUTION**

The symbol and the word **CAUTION** indicate a potentially hazardous situation, which if not avoided, may result in **MINOR INJURY**.

**IMPORTANT :** Indicates that equipment or property damage could result if instructions are not followed.

**NOTE :** Indicates important information or information which is useful for tractor operation.

## Safety Labels

Replace missing or damaged safety signs. Use this operator manual for correct safety sign placement.

There may be additional safety information contained on parts and components sourced from suppliers that is not reproduced in this operator manual.

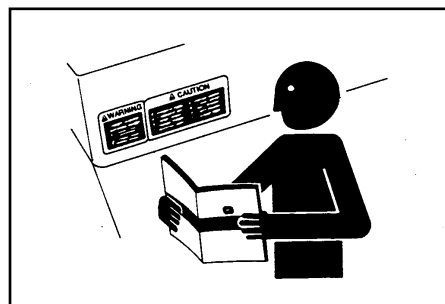

# SAFETY NOTES

## Safety Labels Location

Safety label for warning against hazardous chemicals  
Location: Placed on left-hand side fender



Safety label for warning against thermal hazards (fire or open flame)  
Location: Placed on hood near fuel tank neck



Safety label for use of ultra low sulfur fuel as per EPA Regulation  
Location: Placed on hood near fuel tank neck.

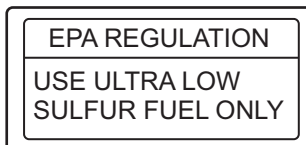

# SAFETY NOTES

Safety label for warning against hot surface

Location: (1). Placed on left hand side of hood, (2). Placed on front axle bracket near exhaust silencer



Safety label for warning against operating PTO below 540 RPM & reading operator's manual.

Location: Placed on left hand side fender.

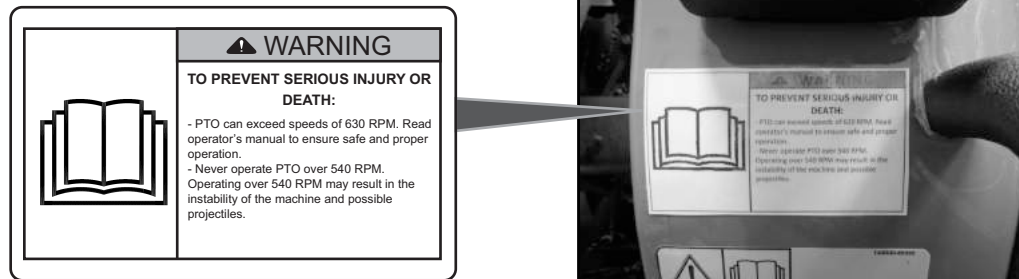

Safety label for reading operator's manual & general safety warnings

Location: Placed on left hand side fender.

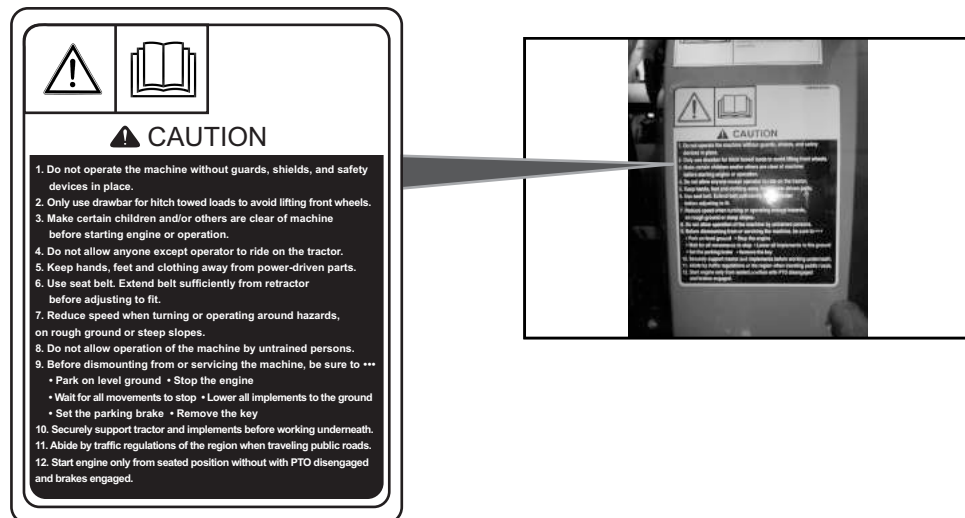

# SAFETY NOTES

Safety labels for reading operator's manual for PTO adjustment procedure

Location: Placed on left hand side fender as shown in photo

PTO Adjustment Procedure	
1. To change/engage PTO, tilt left.	
2. Move forward/Backward for desired position, as indicated on top.	
3. Move right to lock the lever in desired location. Ensure the clutch is disengaged while operating PTO lever.	

PART NO. 3000235168

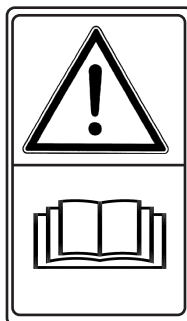

Safety label for warning against:

- (a) Cutting hazards (cutting of fingers or hand)
- (b) Keeping a safe distance from machine

Location: Placed on left hand fender (rear side).

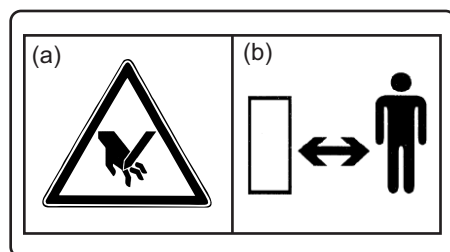

Safety label for safety against pinch/crush hazard

Location: Placed on rear side of the tractor

WARNING		
<p><b>Pinch/Crush Hazard</b> To prevent serious injury or death:</p> <ul style="list-style-type: none"> <li>-Operate controls only from the tractor seat.</li> <li>-Be careful when connecting equipment to tractor. Hands, fingers, feet or other body parts may be pinched if equipment weight shifts.</li> <li>-Do not stand between tractor and equipment when tractor is in gear or parking brake is not engaged.</li> <li>-Stand clear of equipment when raising/lowering or while in use.</li> </ul>		



# SAFETY NOTES

Safety label for warning against extension of arms of three point hitch past the groove

Location: Placed on rear side of the tractor near three point linkage

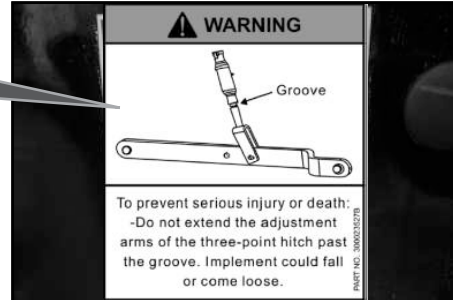
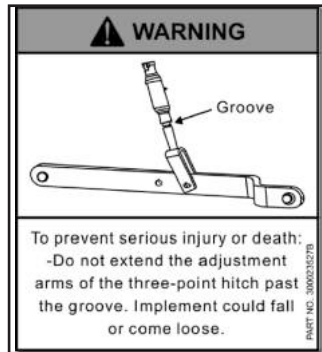

Safety label for not removing safety shields while engine is running

Location: Placed on PTO safety shield at rear side of tractor

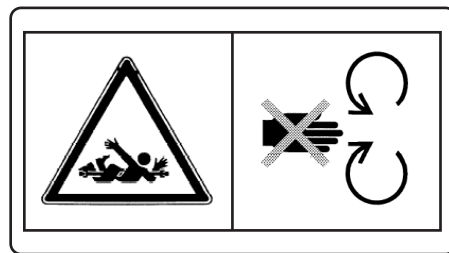

Safety warning label for always locking ROPS in up right position & wearing seat belt unless it has to be folded down to allow operation underneath trees / bushes

Location: Placed on ROPS frame

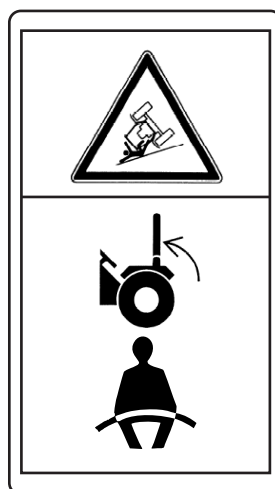



# SAFETY NOTES

Safety warning label for following instructions:

- Do not start engine by shorting across starter terminals or bypassing safety start switch
- Start engine only from seat with transmission and PTO off.

Location: Placed on starter motor at LHS of engine

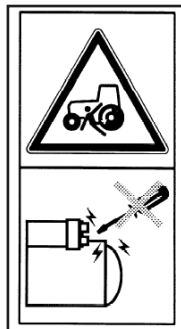

Safety label to stay clear of engine fan and fan belt.

Location: Placed on radiator assembly.

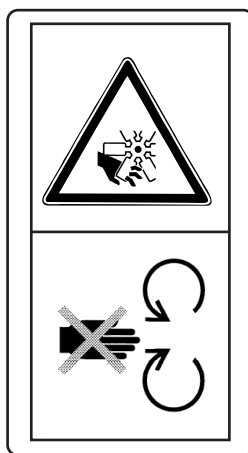

Safety label for warning against various hazard from battery (sticker may vary as per battery manufacturer)

Location: Placed on battery.





# SAFETY NOTES

Safety warning label for use of starting aids  
Location: not available on tractor



## Safety: Prepare For Safe Operation

### Protect yourself:

Wear all the protective clothing and personal safety devices called for by job conditions. Don't take risk hence you may carry/wear the following (fig. 2.1)

- (a) A hard hat.
- (b) Safety glasses, goggles or face shield.
- (c) Hearing protection.
- (d) Respirator or filter mask.
- (e) Inclement weather clothing.
- (f) Reflective clothing.
- (g) Heavy gloves (neoprene for chemical, leather for rough work).
- (h) Safety shoes.

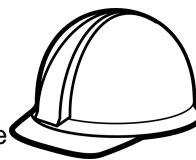

(a)



(b)



(c)



(d)

DO NOT wear loose clothing, jewellery or other items and tie up long hair which could catch on controls or other parts of the tractor.

Learn where fire extinguishers and first aid or emergency equipment is kept and where to get help in a hurry. Make sure you know how to use this equipment.



(e)



(f)



(g)



(h)

# SAFETY NOTES



## SAFE OPERATION

Careful operation is your best insurance against accident.

Read and understand this manual carefully before operating the tractor.

All operators no matter how much experience they may have, should read this and other related manuals before operating the tractor or any implement attached to it.

It is the owner's obligation to instruct all operators a safe operation.

### BEFORE OPERATING THE TRACTOR

#### READ SAFETY INSTRUCTION

Carefully read all safety instructions given in this manual for your safety. Tampering with any of the safety devices can cause serious injuries or death. Keep all safety signs in good condition. Replace missing or damaged safety signs.

Keep your tractor in proper condition and do not allow any unauthorized modifications to be carried out on the tractor, which may impair the function/safety and affect tractor life.

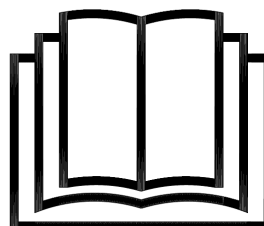

Strictly follow the instructions outlined in the operator's manual of the mounted or trailed machinery or trailer, and not to operate the combination tractor — machine or tractor — trailer unless all instructions have been followed.

### DRIVING THE TRACTOR

1. Watch where you are going especially at row ends, on roads, around trees and low hanging obstacles.
2. To avoid rollovers, drive the tractor with care and at speeds compatible with safety, especially when operating over rough ground, crossing ditches or slopes, and when turning at corners.
3. Lock the tractor brake pedals together when transporting on roads to provide proper wheel braking.
4. Keep the tractor in the same gear when going downhill as used when going uphill. Do not coast or free wheel down hills.
5. Any towed vehicle and/or trailer whose total weight exceeds that of the towing tractor, must be equipped with its own brakes for safe operation.
6. When the tractor is stuck or tires are frozen to the ground, back out to prevent rollovers.
7. Always check overhead clearance, especially when transporting the tractor.

# SAFETY NOTES

## STARTING THE TRACTOR

### Warn bystanders before starting:

Before starting, Walk all around the tractor and any attached equipment. Make sure that no one is under it, on it, or close to it. Let other workers and bystanders know you are starting up and don't start until everyone is clear of the tractor, implements and towed equipment.

Ensure that all bystanders, particularly children are in a safe position before starting the engine.

### Mount and dismount properly:

Always use 'three point contact' with the machine, and face the machine when you mount it. Three point contact means both hands and one foot or one hand and both feet are in contact with the machine at all times during mounting and dismounting.

Clean the soles of your shoes and wipe your hands before climbing on. Use handrails, grip handrails, ladders or steps (as provided) when mounting or dismounting.

NEVER use control levers as a hand hold and NEVER step on foot controls when mounting or dismounting.

NEVER attempt to mount or dismount from a moving tractor. NEVER jump off a tractor in any circumstances.

Adjust the seat, fasten the seat belt (where applicable as outlined in this manual), apply the parking brake and put all controls in neutral before starting up.



Before starting the engine, make sure there is plenty of ventilation. Never operate the engine in a closed building. The exhaust fumes may cause asphyxiation.



## KEEP RIDERS OFF TRACTOR

Do not allow riders on the tractor.

Riders on tractor are subject to injury such as being struck by foreign objects and being thrown off the tractor.



## PRECAUTION TO AVOID TIPPING

Do not drive where the tractor could slip or tip.

Stay alert for holes and rocks in the terrain, and other hidden hazards.

Slow down before you make a sharp turn.

Driving forward out of a ditch or mired condition could cause tractor to tip over backward. Back out these situations if possible.

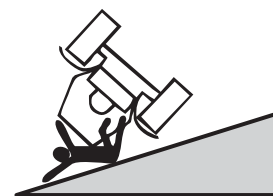

# SAFETY NOTES

## PROHIBITED USE OF TRACTOR DURING OVERTURNING

### Risk of Overturning:

For your safety, tractor is fitted with safety frame and seat belts.

In the event of overturning with a tractor fitted with a safety frame, hold the steering wheel firmly and DO NOT attempt to leave the seat until the tractor has come to rest.

### To avoid side overturns:

- Set the wheel track at the widest setting suitable for the job being done.
- Lock the brake pedals together before driving at transport speeds.
- Reduce speed to match operating conditions. If the tractor is equipped with a front end loader, carry the bucket and load as low as possible.
- Make wide slow turns on reduced speed. DON'T let your tractor bounce. You may lose steering control.
- DON'T pull a load too heavy for your tractor. It could run away on the down slope the tractor could jack knife around a towed load.
- DON'T brake suddenly. Apply brakes smoothly and gradually.
- When going down a slope use the throttle to slow the tractor engine and use the same gear you would use to go up the slope. Shift into gear before you start downhill.
- Engage four-wheel drive (4WD), if fitted, will give you four wheel braking.

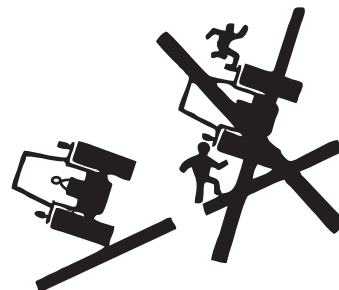

## PARK TRACTOR SAFELY

Before working on the tractor:

Lower all equipments to the ground.

Stop the engine and remove the ignition key.

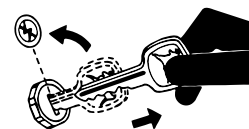

## SAFETY STARTER SWITCH

1. Clutch operated safety switch is provided which allows the starting system to become operational only when the clutch pedal is fully pressed.
2. Do not By-pass this safety switch or work on it. Only Summit authorized servicing dealers are recommended to work on safety starter switch.

## TRACTOR RUNAWAY

1. The tractor can start even if the transmission is in engaged position causing Tractor to runaway and serious injury to the people standing nearby the tractor.
2. Keep transmission in neutral position. Foot brake engaged and PTO lever in disengaged position while attending to safety starter switch or any other work on the tractor.

# SAFETY NOTES

## AVOID HOT EXHAUST

Servicing machine or attachment with engine running can result in serious personal injury. Avoid exposure.

Exhaust parts and streams become very hot during operation. Exhaust gases and components reach temperatures hot enough to burn people, ignite, or melt common materials.



## AVOID HIGH-PRESSURE FLUIDS

Escaping fluid under pressure can penetrate the skin causing serious injury. Keep hands and body away from pinholes and nozzles, which eject fluids under high pressure. If any fluid is injected into the skin, consult your doctor immediately.



## PREVENT BATTERY EXPLOSIONS

Keep sparks, lighted matches, and open flame away from the top of battery.

Battery gas can explode.

Never check battery charge by placing a metal object across the poles.



## ALWAYS USE SAFETY LIGHTS

Use of hazard warning lights and turn signals are recommended when towing equipment on public roads unless prohibited by state or local regulations.





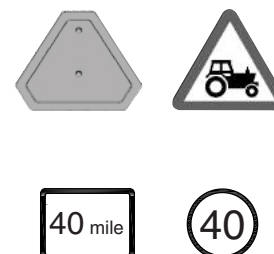

## ROAD REGULATIONS

- When operating your tractor on a public road a number of precautions must be taken.
- Know the route you are going to travel.
- Use caution when towing a load at transport speeds especially if the towed equipment is NOT equipped with brakes.
- Observe all local or national regulations regarding the road speed of your tractor.
- Use extreme caution when transporting on snow-covered or slippery roads.
- Wait for traffic to clear before entering a public road. Beware of blind intersections. Slow down until you have a clear view.

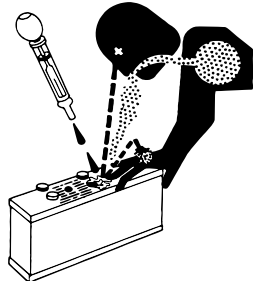

# SAFETY NOTES

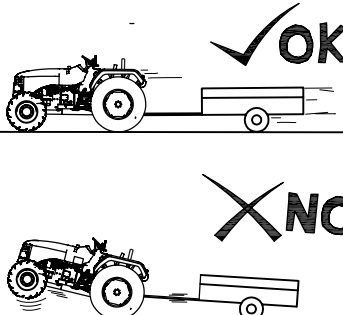
<p style="text-align: center;"><b>PREVENT ACID BURNS</b></p> <p>Sulfuric acid in battery electrolyte is poisonous. It is strong enough to burn skin, cause holes in clothing and cause blindness. For adequate safety always:</p> <ol style="list-style-type: none"> <li>1. Fill batteries in a well-ventilated area.</li> <li>2. Wear eye protection and acid proof hand gloves.</li> <li>3. Avoid breathing direct fumes when electrolyte is added.</li> <li>4. Do not add water to electrolyte as it may splash off causing severe burns.</li> </ol> <p>If you spill acid on yourself, immediately flush your skin with water and flush your eyes for 10-15 minutes. Get medical attention immediately.</p>	
<p style="text-align: center;"><b>HANDLE FUEL SAFELY-AVOID FIRES</b></p> <p>Handle fuel with care; it is highly flammable. Do not refuel the tractor while smoking or near open flame or sparks.</p> <p>Always stop engine before refueling.</p> <p>Always keep your tractor clean of accumulated grease and debris.</p> <p>Always clean up spilled fuel.</p>	
<p style="text-align: center;"><b>SERVICE TRACTOR SAFELY</b></p> <p>Do not wear a necktie, scarf or loose clothing when you work near moving parts. If these items get caught, severe injury could result.</p> <p>Remove rings and other jewelry to prevent electrical shorts and entanglement in moving parts.</p>	
<p style="text-align: center;"><b>STAY CLEAR OF ROTATING SHAFTS</b></p> <p>Entanglement in rotating shaft can cause serious injury or death.</p> <p>Keep PTO shield in place at all times.</p> <p>Wear close fitting clothing. Stop the engine and to sure PTO drive is stopped before making adjustments, connections, or cleaning out PTO driven equipment.</p>	
<p style="text-align: center;"><b>GENERAL OPERATING HAZARDS</b></p> <ul style="list-style-type: none"> <li>• Three point hitch and side mounted implements make a much larger arc when turning that towed equipment. Make certain to maintain sufficient clearance for safe turning.</li> <li>• When using attachments or implements with the tractor, be sure to thoroughly read the operator instruction book for that attachment or implement and follow its safety instructions.</li> <li>• Pull only from the approved drawbar. Towing or attaching to other locations may cause the tractor to overturn.</li> <li>• Improper use of the drawbar, even if correctly positioned, may cause the tractor to overturn to the back.</li> <li>• DO NOT overload an attachment or towed equipment. Use proper counterweights to maintain tractor stability. Hitch loads to the drawbar only.</li> </ul>	

# SAFETY NOTES

## PRACTICE SAFE MAINTENANCE

- Understand service procedure before doing work.
- Keep the surrounding area of the tractor clean and dry.
- Do not attempt to service tractor when it is motion.
- Keep body and clothing away from rotating shafts.
- Always lower equipment to the ground. Stop the engine.
- Remove the key equipment to the ground. Stop the engine.
- Securely support any tractor elements that must be raised for service work.
- Keep all parts in good condition and properly installed.
- Replace worn or broken parts. Replace damage/missing decals.
- Remove any buildup of grease or oil form the tractor.
- Disconnect battery ground cable (-) before making adjustments on electrical system or welding on tractor.



## SAFETY TIPS DURING MAINTENANCE

1. At least on a daily check all oil levels. Water level in the radiator and electrolyte level in the battery and perform services according to the service schedule.
2. Ensure tire pressure are even and the correct pressure for the job being done is maintained.
3. Check to ensure that the all controls and preventive mechanisms of the tractor and implement work correctly and effectively.
4. Ensure that an adequate set of the correct tools is available for maintenance and minor repairs.
5. Ensure that all service work and repairs are carried out on a flat area with a concrete or similar floor.  
Do not carry out service work on tractor until it is switched off, and the parking brake applied and wheels chocked. Where a tractor is stored in a confined area, ensure that the area is well ventilated as exhaust gases are very harmful, and can cause death.
6. Do not work under lifted implements under operation.
7. When changing wheels or tires ensure that a suitable wheel stand is placed under the axle prior to removing the wheel and the wheels are chocked.
8. Where guards or shields need to be removed to perform a service or repair, ensure that the guard or shield is correctly reinstalled before starting the tractor.
9. Never refuel near a naked flame or with an overheated engine. Ensure engine is off before refueling.
10. The cooling system operates under pressure, take care when removing the radiator cap a hot engine to prevent being scalded by steam or hot water. Do not add water in the radiator when then engine is hot. Add water to the radiator only after the engine cools down completely.
11. To prevent fire keep the tractor including the engine clean and free from flammable material and well away from fuels and other flammable material.

# SAFETY NOTES

## PREPARE FOR EMERGENCIES

Be prepared if a fire starts.

Keep a first aid kit and fire extinguisher ready.

Keep emergency numbers for doctors, ambulance service, hospital, and fire department near telephone or mobile phone.

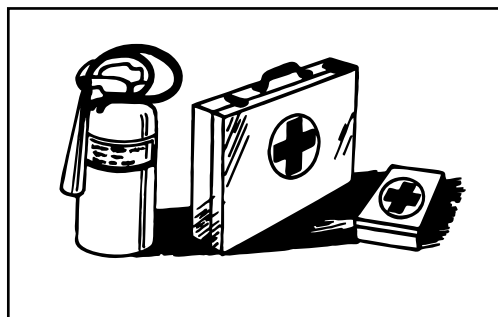

## PROTECT AGAINST NOISE

Prolonged exposure to loud noise can cause impairment or loss of hearing.

Wear a suitable protective device such as earmuffs or earplugs to protect against uncomfortable loud noises.

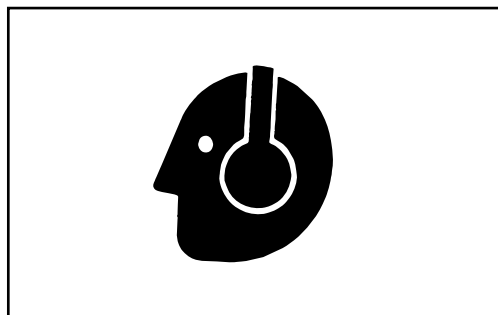

## SAFE HANDLING OF STARTING FLUID

Starting fluid is highly flammable.

Keep all sparks and flame away when using it. Keep starting fluid away from batteries and cables.

To prevent accidental discharge when storing the pressurized can, keep the cap on the container, and store in a cool, protected location.

Do not puncture a starting fluid container.



## KEEP ROPS INSTALLED PROPERLY

Make sure that all parts are reinstalled correctly if the roll-over protective structure (ROPS) is loosened or removed for any reason. Tighten mounting bolts to proper torque.

The protection offered by ROPS will be impaired if ROPS is subjected to structural damage, is involved in an overturn incident, or is in any way altered by welding, bending, drilling, or cutting. A damaged ROPS should be replaced, not reused.

The seat is part of the ROPS safety zone. Replace only with seat approved for your tractor. Any alteration of the ROPS must be approved by the manufacturer.

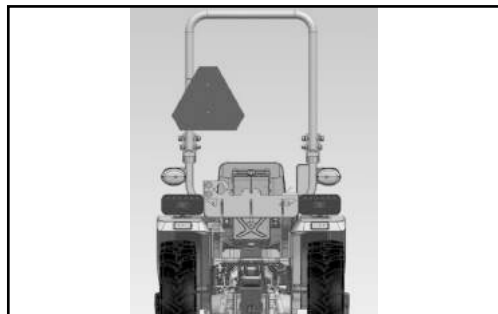



## SAFETY NOTES

### AVOID STATIC ELECTRICITY RISK WHEN REFUELING

The removal of sulfur and other compounds in ultra-low sulfur diesel (ULSD) fuel decreases its conductivity and increases its ability to store a static charge.

Refineries may have treated the fuel with a static dissipating additive. However, there are many factors that can reduce the effectiveness of the additive over time.

Static charges can build up in ULSD fuel while it is flowing through fuel delivery systems. Static electricity discharge when combustible vapors are present could result in a fire or explosion.

Therefore, it is important to ensure that the entire system used to refuel your machine (fuel supply tank, transfer pump, transfer hose, nozzle, and others) is properly grounded and bonded. Consult with your fuel or fuel system supplier to ensure that the delivery system is in compliance with fueling standards for proper grounding and bonding practices.

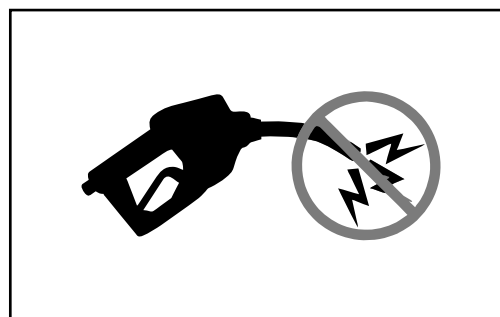

### PREVENTION OF FIRE

Tractor should be regularly inspected and cleaned to lower the risk of fire.

- During normal operation of tractor, crop material, hay or other debris can be accumulated. This is likely to happen when operating in dry conditions. Any such build up must be removed to ensure proper machine function and to reduce the risk of fire. The tractor must be inspected and cleaned periodically throughout the day.
- Birds and other animals may build nests or bring other flammable materials into the engine compartment or onto the exhaust system. The tractor should be inspected and cleaned prior to the first use each day.
- Regular and thorough cleaning of the tractor combined with other routine maintenance procedures listed in this operator manual reduce the risk of fire and the chance of costly downtime.
- Do not store fuel container where there is an open flame, spark, or pilot light such as within a water heater or other appliance.
- Check fuel lines, tank, cap, and fittings frequently for damage, cracks or leaks. Replace, if necessary.

Follow all operational and safety procedures mentioned on the tractor and the operator manual. Be careful of hot engine and exhaust components during inspection and cleaning. Before carrying out any inspection or cleaning, always shut off the engine, place the transmission in park or set parking brake, and remove the key. Removal of the key will prevent others from starting the tractor during inspection and cleaning.

# SAFETY NOTES

## IN CASE OF FIRE



**CAUTION: Avoid personal injury.**

Immediately stop the tractor at the first sign of fire. Fire may be identified by the smell of smoke or sight of flames. As fire grows and spreads rapidly, get off the tractor immediately and move safely away from the fire. Do not return to the tractor! The number one priority is safety.

Call the fire department. A portable fire extinguisher can put out a small fire or contain it until the fire department arrives; but portable extinguishers have limitations. Always put the safety of the operator and bystanders first. If attempting to extinguish a fire, keep your back to the wind with an unobstructed escape path so you can move away quickly if the fire cannot be extinguished.

Read the instructions on fire extinguisher and become familiar with their location, parts, and operation before a fire starts. Local fire departments or fire equipment distributors may offer fire extinguisher training and recommendations.

If your extinguisher does not have instructions, follow these general guidelines:

- Pull the pin. Hold the extinguisher with the nozzle pointing away from you, and release the locking mechanism.
- Aim low. Point the extinguisher at the base of the fire.
- Squeeze the lever slowly and evenly.
- Sweep the nozzle from side-to-side.
- 

## PROPER USE OF SEAT BELT & ROPS

- Avoid crushing injury or death during rollover.
- Keep the ROPS in the fully extended and locked position. USE a seat belt when you operate with a ROPS in the fully extended position.
- Hold the latch and pull the seat belt across the body.
- Insert the latch into the buckle. Listen for a click.
- Tug on the seat belt to make sure that the belt is securely fastened.
- Snug the seat belt across the hips.
- If this machine is operated with the ROPS folded (for example, to enter a low building), drive with extreme caution. DO NOT USE a seat belt with the ROPS folded.
- Return the ROPS to the raised, fully extended position as soon as the machine is operated under normal conditions.

**NOTE:** 1). Replace entire seat belt if mounting hardware, buckle, belt, or retractor show signs of damage.  
2). Inspect seat belt and mounting hardware at least once a year. Look for signs of loose hardware or belt damage, such as cuts, fraying, extreme or unusual wear, discoloration, or abrasion. Replace only with genuine parts.

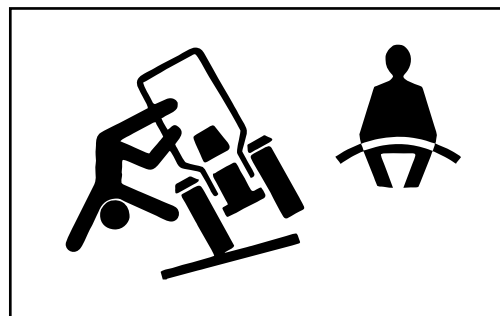
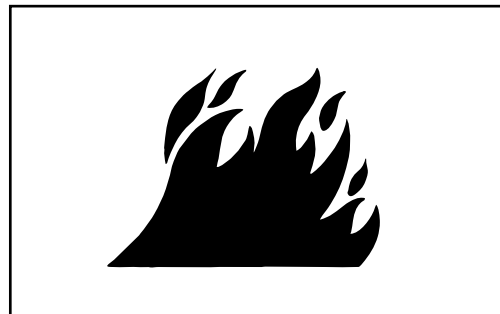

# SAFETY NOTES

## CORRECT USE OF HANDHOLDS AND STEPS

While getting ON and OFF the tractor, always face the tractor. Maintain 3 point contact with steps, handholds, handrails.

Use extra care in slippery conditions due to mud, snow, or moisture. Keep steps clean and free of grease or oil. Never jump while de-boarding the tractor. Never mount or dismount a moving tractor.

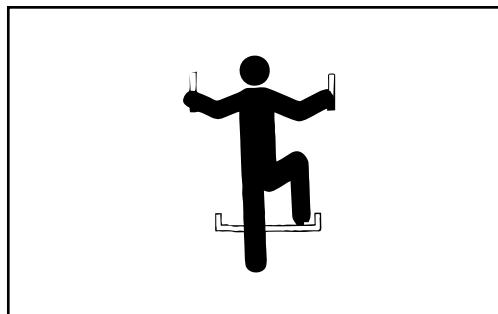

## LIMITED USE IN FORESTRY OPERATION

The intended use of tractors when used in forestry operations is limited to tractor-specific applications like transport, stationary work such as log splitting, propulsion, or operating implements with PTO, hydraulic, or electrical systems.

These are applications where normal operation does not present a risk of falling or penetrating objects. Any forestry applications beyond these applications, such as forwarding and loading, requires fitment of application-specific components including falling object protective structure (FOPS) and/or operative protective structures (OPS).

## USE SAFETY LIGHT AND DEVICES

Prevent collisions between other road users, slow moving tractors with attachments or towed equipment, and self-propelled machines on public roads. Frequently check for traffic from the rear, especially in turns, and use turn signal lights.

Use headlights, flashing warning lights, and turn signals day and night. Follow local regulations for equipment lighting and marking. Keep lighting and marking visible, clean, and in good working order. Replace or repair lighting and marking that has been damaged or lost.

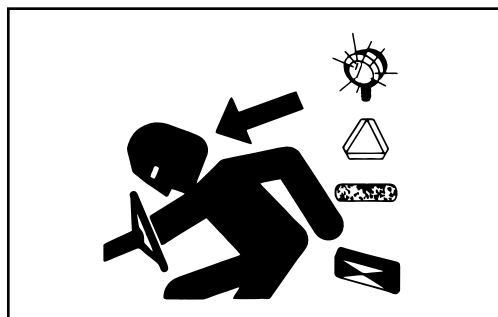

## USE OF SAFETY CHAIN

A safety chain will help control drawn equipment should it accidentally separated from the drawbar. Use a chain with a strength rating equal to or greater than the gross weight of the towed machine.

Using the appropriate adapter parts, attach the chain to the tractor drawbar support or other specified anchor location. Provide only enough slack in the chain to permit turning.

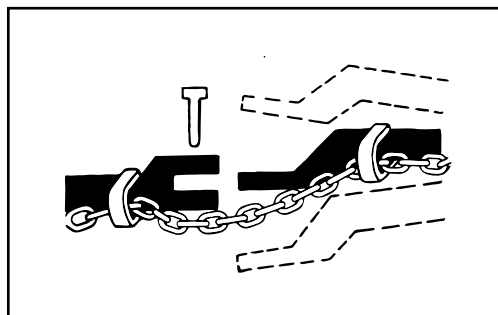

# SAFETY NOTES

## FREEING A MIRE D TRACTOR

Attempting to free a mired tractor can involve safety hazards such as the mired tractor tipping rearward, the towing tractor overturning, and the tow chain or tow bar (a cable is not recommended) failing and recoiling from its stretched condition.

Back your tractor out if it gets mired down in mud. Unhitch any towed implements. Dig mud from behind the rear wheels. Place boards behind the wheels to provide a solid base and try to back out slowly. If necessary, dig mud from the front of all wheels and drive slowly ahead.

If necessary to tow with another unit, use a tow bar or a long chain (a cable is not recommended). Inspect the chain for flaws. Make sure all parts of towing devices are of adequate size and strong enough to handle the load.

Always hitch to the drawbar of the towing unit. Before moving, clear the area of people. Apply power smoothly to take up the slack: a sudden pull could snap any towing device causing it to whip or recoil dangerously.

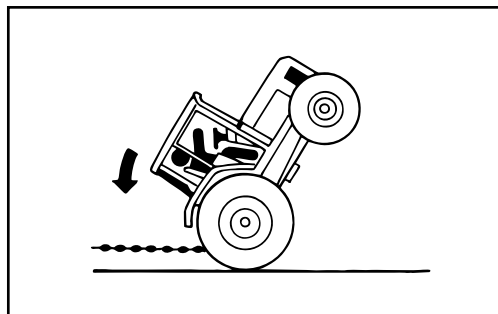

## AVOID CONTACT WITH AGRICULTURAL CHEMICALS

If pesticide use instructions require respiratory protection, wear an appropriate respirator.

Store the respirator in a closed box or some other type of sealable container, such as a plastic bag.

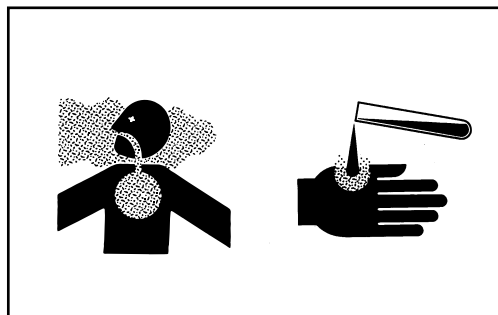

## AVOID HEATING NEAR PRESSURIZED FLUID LINES

Flammable spray can be generated by heating near pressurized fluid lines, resulting in severe burns to yourself and bystanders. Do not heat by welding, soldering, or using a torch near pressurized fluid lines or other flammable materials. Pressurized lines can accidentally burst when heat goes beyond the immediate flame area.

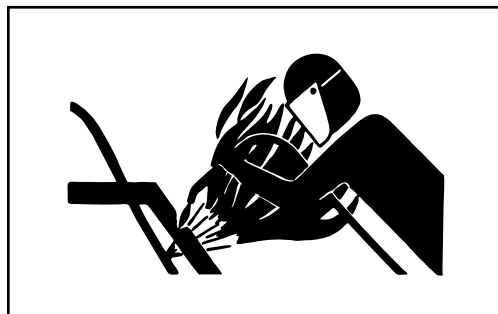

## SAFETY NOTES

### HANDLE ELECTRONIC COMPONENTS AND BRACKETS SAFELY

Falling while installing or removing electronic components mounted on equipment can cause serious injury. Use a ladder or platform to easily reach each mounting location. Use sturdy and secure footholds and handholds. Do not install or remove components in wet or icy conditions.



### SUPPORT MACHINE PROPERLY

Always lower the attachment or implement to the ground before you work on the machine. If the work requires that the attachment be lifted, provide secure support for them. If left in a raised position, hydraulic supported devices can settle or leak down.

Do not work under the tractor which is supported solely by a jack.

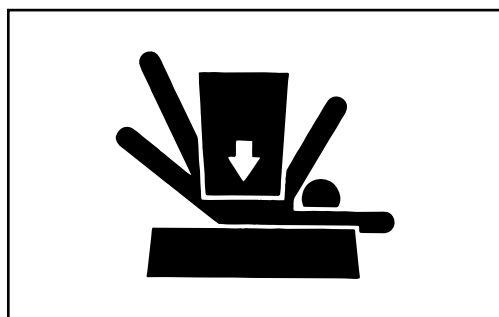

### PREVENT TRACTOR RUNAWAY

Avoid possible injury or death from tractor runaway.

Do not start engine by shorting across starter terminals. Tractor will start in gear if normal circuitry is bypassed.

NEVER start engine while standing on ground. Start engine only from operator's seat, with transmission in neutral.

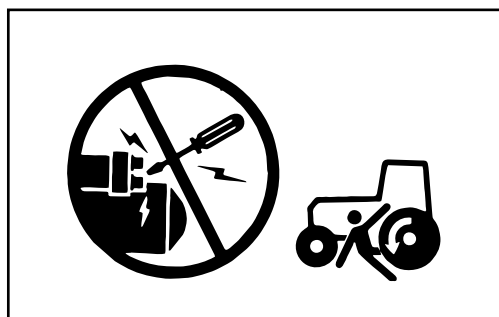

### TRANSPORT TRACTOR SAFELY

A disabled tractor is best transported on a flatbed carrier. Use chains to secure the tractor to the carrier. The axles and tractor frame are suitable attachment points.

Before transporting the tractor on a low-loader truck or flatbed rail wagon, make sure that the hood is secured over the tractor engine.

Never tow a tractor at a speed greater than 6 mph (10 km/h). An operator must steer and brake the tractor under tow.

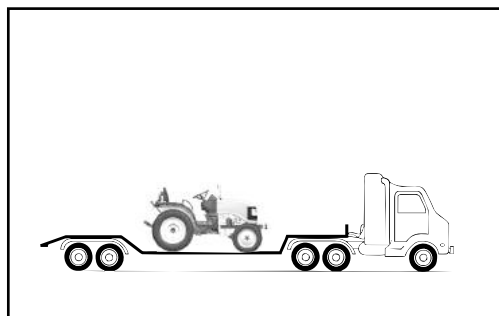

# SAFETY NOTES

## SERVICE TIRES SAFELY

Explosive separation of a tire and rim parts can cause serious injury or death.

Do not attempt to mount a tire unless you have the proper equipment and experience to perform the job.

Always maintain the correct tire pressure. Do not inflate the tires above the recommended pressure. Never weld or heat a wheel and tire assembly. The heat can cause an increase in air pressure resulting in a tire explosion. Welding can structurally weaken or deform the wheel.

When inflating tires, use a clip-on chuck and extension hose long enough to allow you to stand to one side and NOT in front of or over the tire assembly. Use a safety cage if available.

Check wheels for low pressure, cuts, bubbles, damaged rims, or missing lug bolts and nuts.



## TIGHTENING WHEEL RETAINING BOLTS/NUTS

Torque wheel retaining bolts/nuts at the intervals specified in the maintenance section.

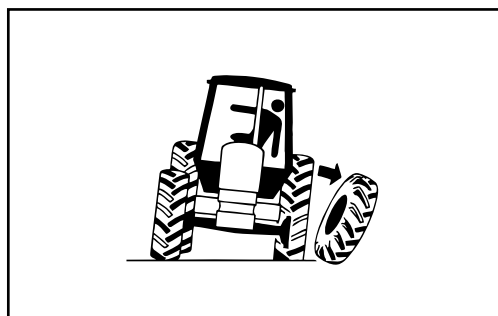

## STORE ATTACHMENTS SAFELY

Stored attachments such as dual wheels, cage wheels, and loaders can fall and cause serious injury or death.

Securely store attachments and implements to prevent falling. Keep playing children and bystanders away from storage area.

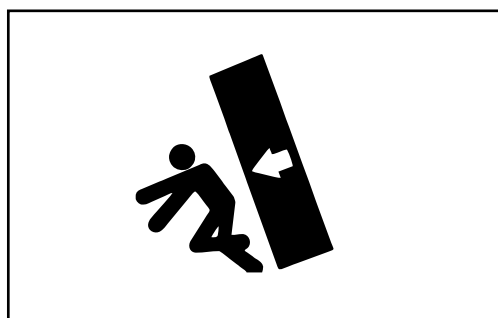

## DISPOSE OF WASTE PROPERLY

It is illegal to pollute drains, water courses or soil. Use authorized waste disposal facilities, including civic amenity sites and garages providing facilities for disposal of used oil. If in doubt, contact your local authority for advice.

To get to know the correct methods to dispose of oils, filters, tires etc. contact your authorized servicing dealer or the local agency for waste recycling.

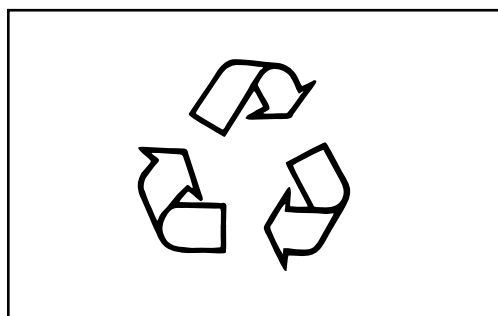

# SAFETY NOTES

## DISPOSAL OF THE TRACTOR:

The tractor is made up of parts subjected to rules and laws for their disposal. When the tractor is not used any more, it must be disposed of through proper agencies according to such rules. Do not pollute the environment with the tractor or its parts.

## SAFETY WHILE OPERATING LOADER ATTACHMENTS

- The equipment must only be used by authorized and trained personnel who, beforehand, must read and understand these instructions and become familiar with the equipment controls and their operation.
- Before operation, check all functions of the equipment and attachment going to be used.
- The equipment must be used by people aged more than 18 years, having the qualities required by the national legislation.
- Before or during work, do not take alcoholic beverages, medicines or other substances that may alter your psycho-physical conditions and affect your working abilities.
- The equipment must only be used for the applications intended by the manufacturer. An improper use may cause serious damage and injury.
- Always check the weight and nature of the load to be handled and the stability of the tractor in relation to the ground conditions.
- Couple the equipment only to tractors fitted with adequate rollover protective structures.
- Do not use the equipment on steep slopes.
- Before pressuring the hydraulic circuit of the equipment, make sure that the hydraulic hoses are intact and properly connected.
- Do not use the equipment to lift or transport people.
- Do not use the equipment as a working platform.
- Never transit or halt under suspended loads or under parts of the equipment supported solely by hydraulic jacks or ropes.
- Do not use the equipment if problems or anomalous vibrations are noticed.

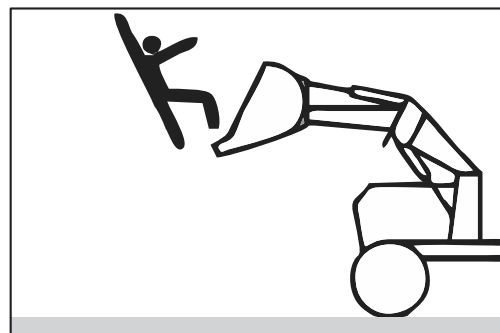
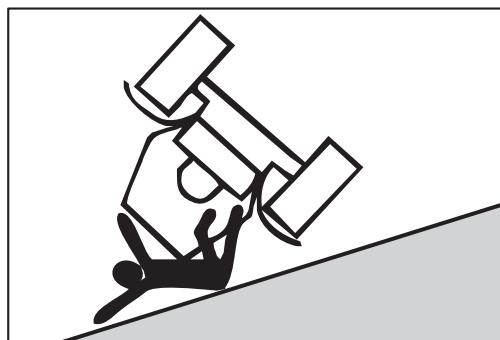

## SAFETY NOTES

- Do not use the equipment to handle loads without using an appropriate attachment; for instance, do not use a bucket to lift a round bale. Be very careful to raised loads.

**FOR INSTRUCTIONS AND SAFETY RULES FOR OPERATING LOADER, FOLLOW INSTRUCTIONS AVAILABLE ON LOADER'S OPERATOR MANUAL.**

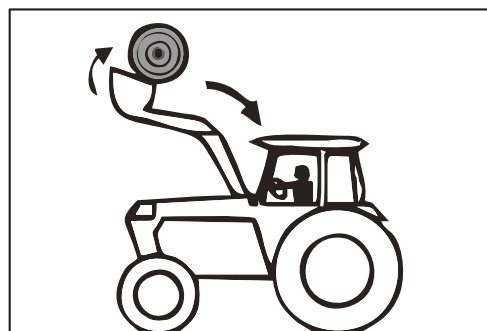
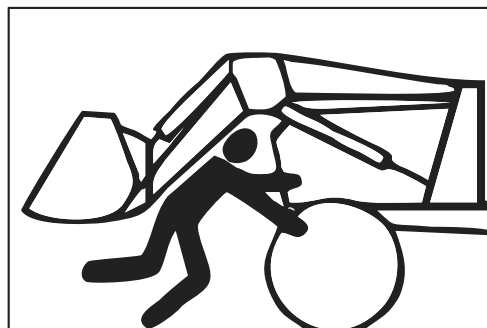

### SAFETY FROM LIGHTNING STRIKE



**DANGER**

Lightning strikes injure and kill hundreds of people each year. Follow these precautions to help keep you safe when the weather turns bad:

- As soon as you hear thunder, shut off and put away equipment and move indoors. When you are able to hear thunder, you can be struck by lightning. Lightning can strike even when it's not raining.
- A sturdy building provides the best protection.
- Listen to the radio for weather updates and storm warning.

### NOISE & VIBRATION LEVELS

The value of the noise at the operator's ear, measured according to standard 167/2013 (EU) and/or as per Directive 2009/76/EC(1) of the European Parliament and of the Council and the noise of the tractor in motion measured according to Annex VI to Directive 2009/63/EC (2) of the European Parliament and of the Council and/or 167/2013 (EU): Operator ear level:- Less than 86 dB. Noise at By standard level (when tractor is in motion & when tractor is stationary):- Less than 85 dB.

The value of the vibration level measured according to standard 167/2013 (EU) and/or according to Council Directive 78/764/EEC(3) is less than 1.25 m/s<sup>2</sup>.



# INSTRUMENTS & CONTROLS

## Tractor Controls- SUMMIT TX25

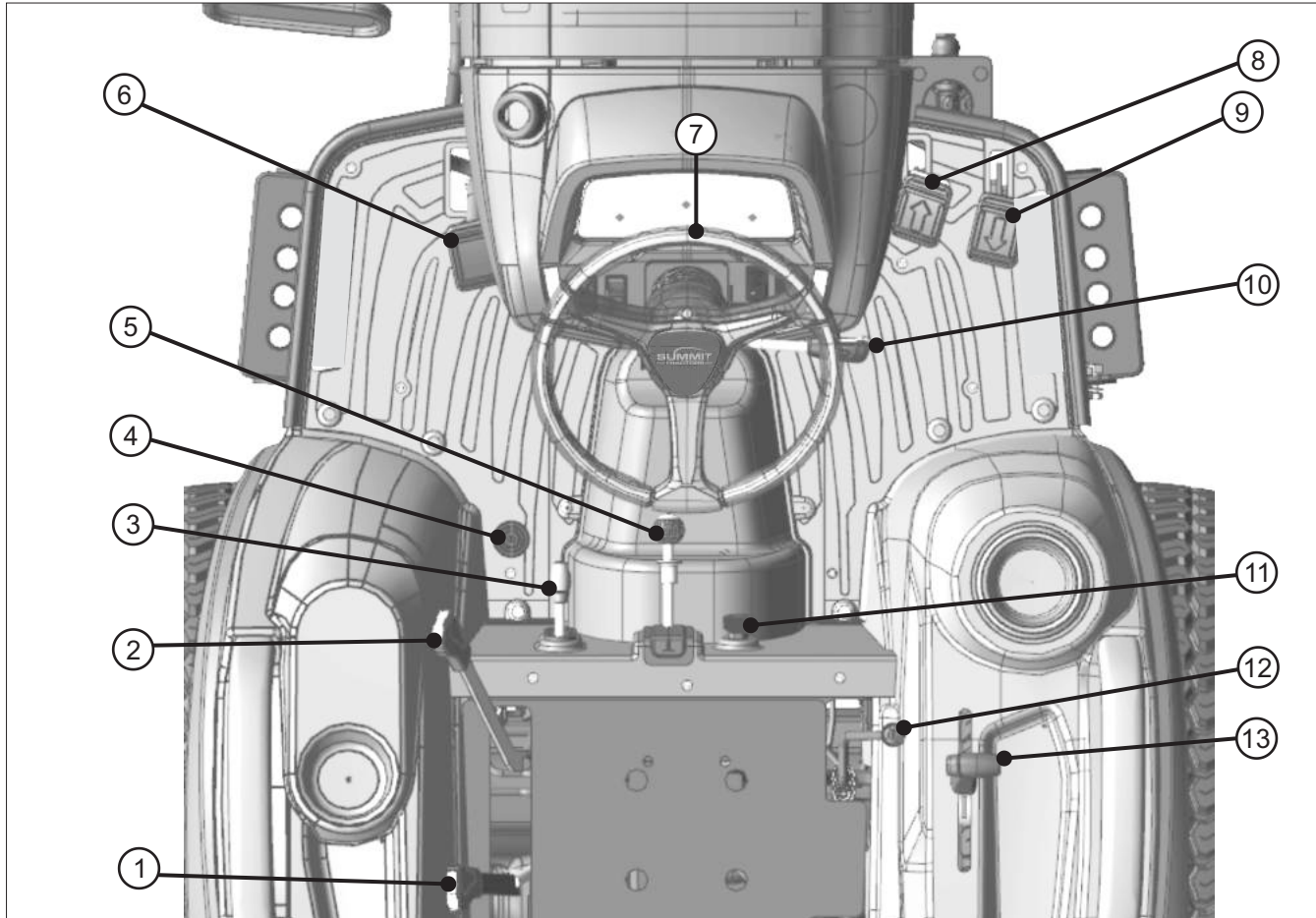

1	PTO Shifter Lever
2	Hi-Low Lever
3	2WD/4WD Lever
4	Differential Lock
5	Parking Brake Lever
6	Brake Pedal
7	Steering Wheel

8	Forward Speed Control Pedal
9	Reverse Speed Control Pedal
10	Hand Throttle Lever
11	Response Valve / Transport Lock
12	DCV Lever
13	Hydraulic Control Lever

# INSTRUMENTS & CONTROLS

## Instrument Cluster

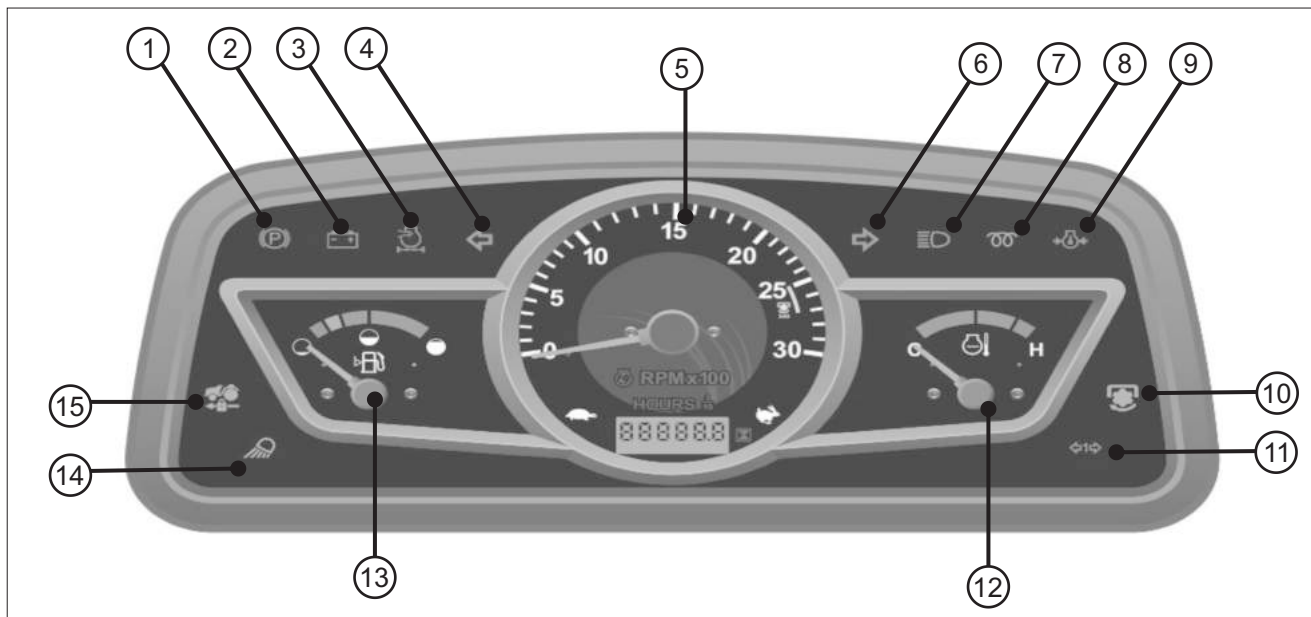

1		Parking Brake Indicator
2		Battery Charging Indicator
3		Air Cleaner Clogging Indicator
4		Left Turn Indicator
5		RPM & Hour Meter
6		Right Turn Indicator
7		High Beam Indicator
8		Glow Plug Indicator
9		Oil Pressure Indicator
10		PTO Monitor Lamp
11		Turn Trailer Indicator
12		Temperature Gauge
13		Fuel Gauge
14		Working Lamp Indicator
15		Cruise On-Off Indicator

# INSTRUMENTS & CONTROLS

## Parking Brake Indicator

It glows when parking brake lever is in engaged condition.

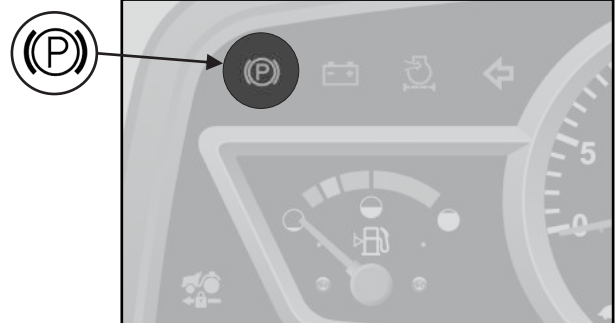

## Battery Charge Indicator

This indicator indicates that either battery is being charged or not. Refer the below given observations with respect to different

CONDITIONS			Battery Charging System Functioning
IGNITION SWITCH	ENGINE	INDICATOR	
ON	OFF	GLOW	OK
ON	OFF	OFF	Charging system/battery is defective, Get both thing checked from electrician
ON	Start/Running	OFF	Battery being charged
ON	Start/Running	GLOW	Charging system is defective/battery is draining out, get the charging system checked from electrician.

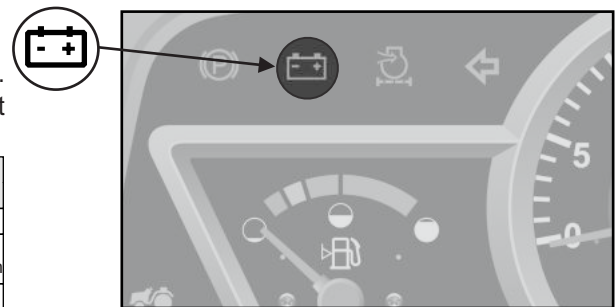

## Air Filter Clogging Indicator

This light will glow when the air filter is clogged. Clean the air filter element immediately with air pressure if this light is glowing.

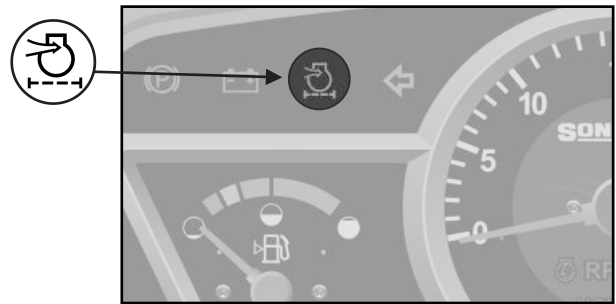

## Left Turn Indicator

It glows when the left side indicator is switched ON.

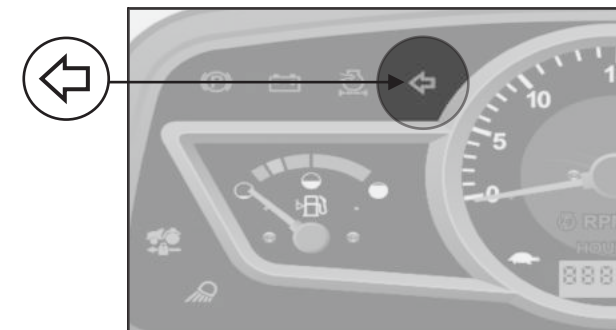

## INSTRUMENTS & CONTROLS

### Right Turn Indicator

It glows when the right side indicator is ON.

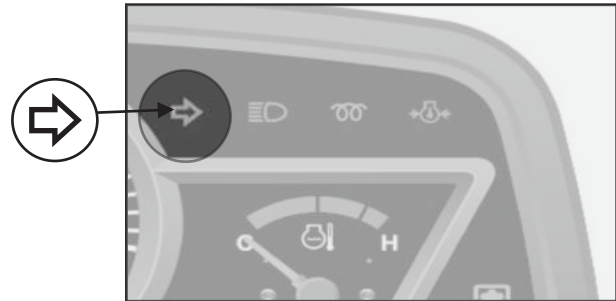

### High Beam Indicator

This light glows when head lights are in high beam mode.



### Cold Start Indication

It glows when ignition heater is ON at second position of the starting key.

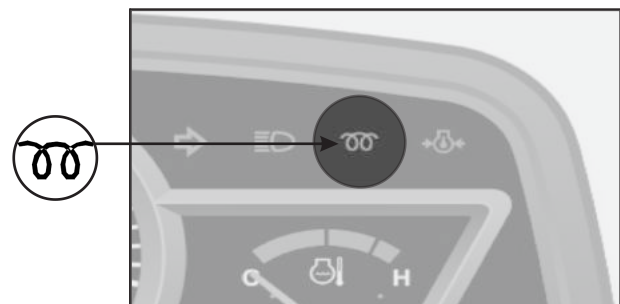

# INSTRUMENTS & CONTROLS

## Engine Oil Pressure Indicator

This indicates oil pressure of lubricating oil in the engine. If this glows this means oil pressure is low and follow the below procedure :

1. Stop your tractor to the side of road on leveled surface.
2. Wait for sufficient time after stopping the engine to get down the oil from gallery to oil sump.
3. Pull out the dipstick, wipe off oil with a clean cloth.
4. Insert the dipstick, fully into the oil level gauge guide, then pull out the gauge again. The correct oil level is between the max. & min. marks on the dipstick.
5. If the oil level is low, remove the oil filler cap (1) and add recommended oil up to the max. level.
6. Install the oil filler cap after adding oil.
7. Check the oil pan and other parts for oil leakage.
8. Start the engine, allow it to run idle and don't accelerate engine immediately. If indicator glows again, then contact your nearest authorized servicing dealer.

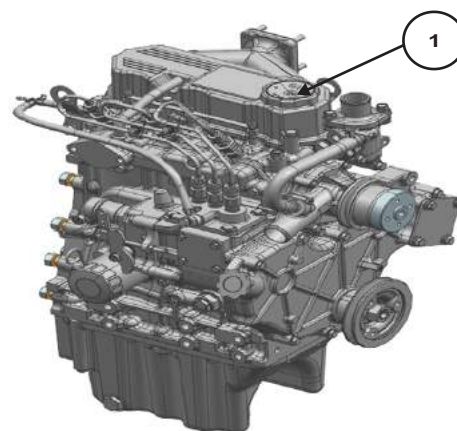
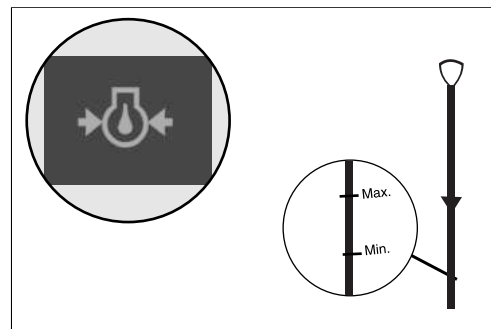

**IMPORTANT:** Do not operate the engine if there is no oil pressure. This may damage engine parts.

## Temperature Gauge:

This gauge indicates temperature of engine coolant, GREEN zone indicates normal temperature and RED zone indicates engine overheating. If the needle moves beyond normal range, towards RED zone, follow the procedure:

1. Drive safely to the side of road and stop your tractor.
2. Allow the engine to run idle.
3. If the temperature does not go down after running it in idle condition for a minute, shut off the engine.
4. Visually inspect the fan belt for looseness, breakage and all water hose connections for leak.
5. If the fan belt is OK and no coolant leak is noticed check the coolant level.
6. Add coolant if required otherwise contact your nearest authorized servicing dealer.

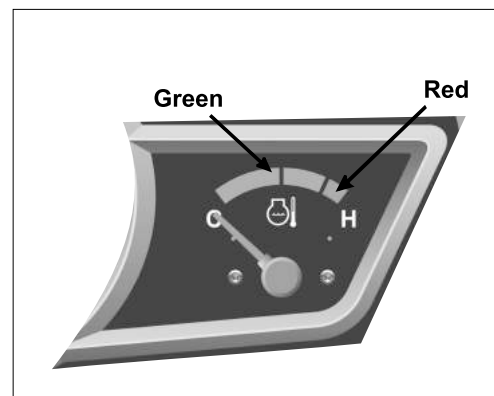

**WARNING**

Do not remove the radiator cap when the engine and radiator are hot. Hot coolant and steam may blow out under pressure, which could cause serious injury. The cap should only be taken off when the coolant temperature has lowered.  
Necessary precaution to be taken while opening the radiator cap.

# INSTRUMENTS & CONTROLS

## PTO Monitor Lamp

This lamp will turn ON, when PTO clutch engaged.

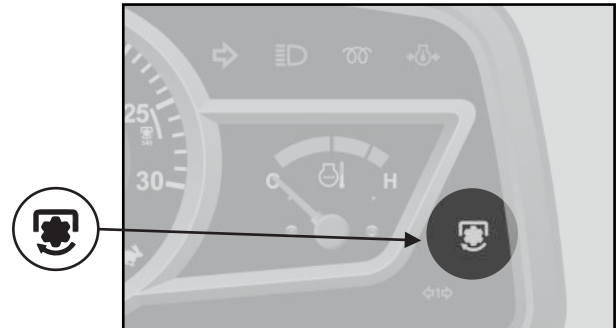

## Trailer Turn Indicator

This indicates the working of left and right side indicators lights of the trailer attachment. It glows all the time when hazard switch is ON. 7-Pin socket is used for connection of trailer lights.

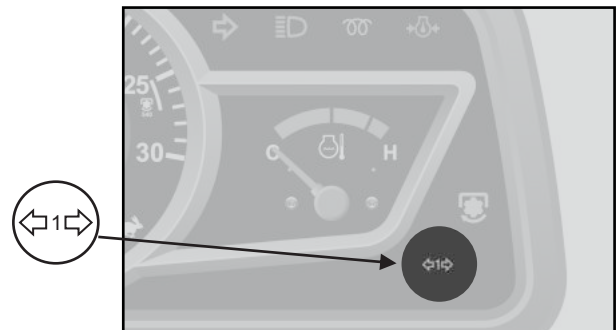

## Engine RPM and Hour Meter

Needle of this meter indicates speed of engine in revolution per minute and the hour meter indicates the number of hours worked by the engine.

**NOTE:** Hour meter reading may defer from actual hour (as per clock). This purely depends on engine RPM.



# INSTRUMENTS & CONTROLS

## Work Lamp Indicator

This glows when work lamp is ON.

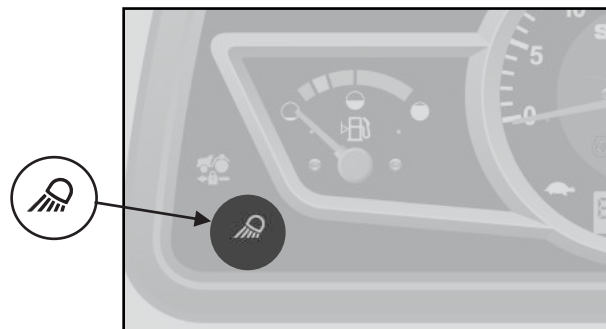

## Fuel Gauge

Fuel gauge gives an approximate indication of the quantity of fuel in fuel tank. If the needle enters in RED zone, refill the fuel tank.

Ensure Min. 1.6 U.S. Gallon [6 Liter] of fuel in fuel tank to avoid air locking.

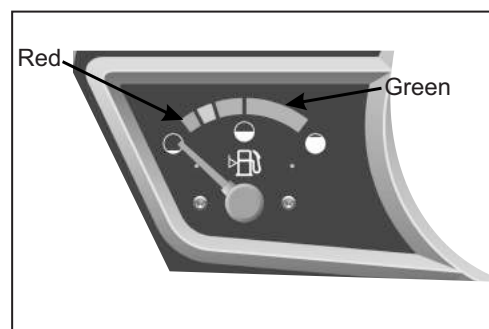

## Cruise Control

This light glows when cruise is ON.

Cruise control switch is for tractor operating efficiency and operator's comfort,

This option provide a constant forward operating speed by mechanically holding the cruise control lever at the selected position.

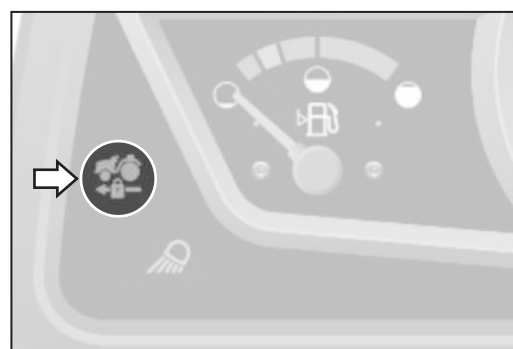



# INSTRUMENTS & CONTROLS

## Dashboard Controls :

- (1) Hazard Warning Light Switch
- (2) Cruise ON-OFF Switch
- (3) Combination Switch
- (4) Ignition Switch
- (5) PTO ON-OFF Switch

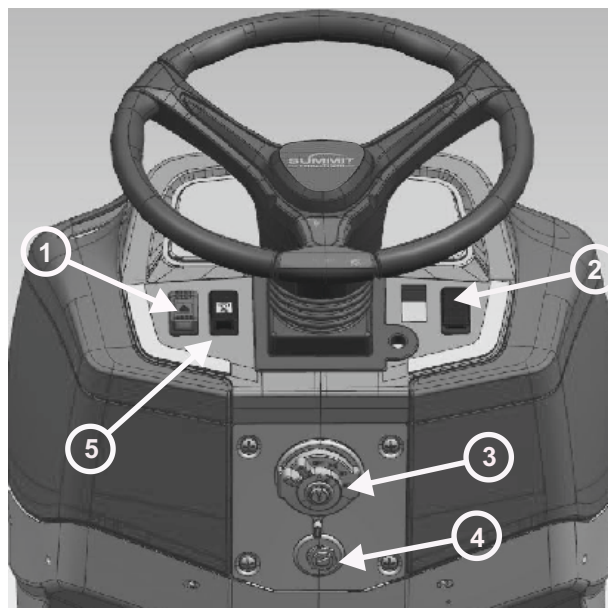

## Hazard Warning Light Switch :

Purpose of the hazard switch is as follows.

1. All the four lights blinking, indicates that driver has no control on tractor.
2. Mechanical defects in the tractor.  
Push this switch to blink all indicators in HAZARD situation to alert others.

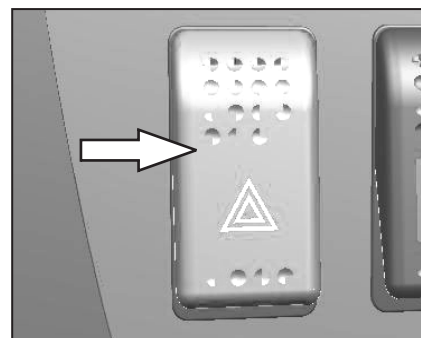

## Combination Switch :

### Side Indicator Switch (A):

This switch is used for indicating the vehicle turn. Move turn signal lever left to indicate left (L) hand turn or right (R) for right hand turn. Indicator lights will flash according.

### Horn Switch (B):

Press this switch to blow the horn.

### Head Light and Parking Light Switch (C):

This switch illuminates all lights (parking light, head light, high beam, low beam) with the clockwise rotation.

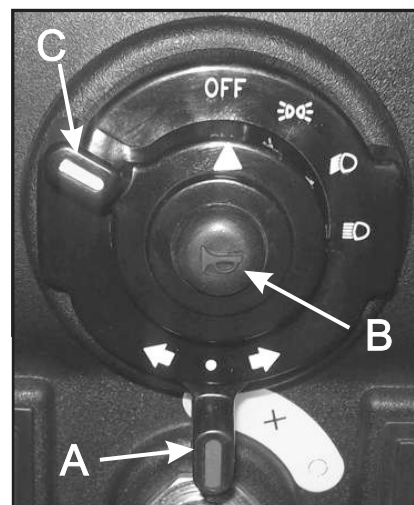



# INSTRUMENTS & CONTROLS

<p><b>OFF Position</b> All lights are off.</p>	<p><b>1<sup>st</sup> Position (Clockwise)</b> With 1<sup>st</sup> click Stop parking lights, instrument panel lights and tail lights will glow.</p>	<p><b>2<sup>nd</sup> Position (Clockwise) :</b> With 2<sup>nd</sup> click Stop head lights low beam), instrument panel lights, parking lights and tail light will glow</p>	<p><b>3<sup>rd</sup> Position (Clockwise) :</b> With 3<sup>rd</sup> click Stop head lights (high beam) instrument panel lights, parking lights and tail light will glow.</p>	<p><b>Horn :</b> Press the combination switch to blow the horn.</p>
--	---	--	--	---

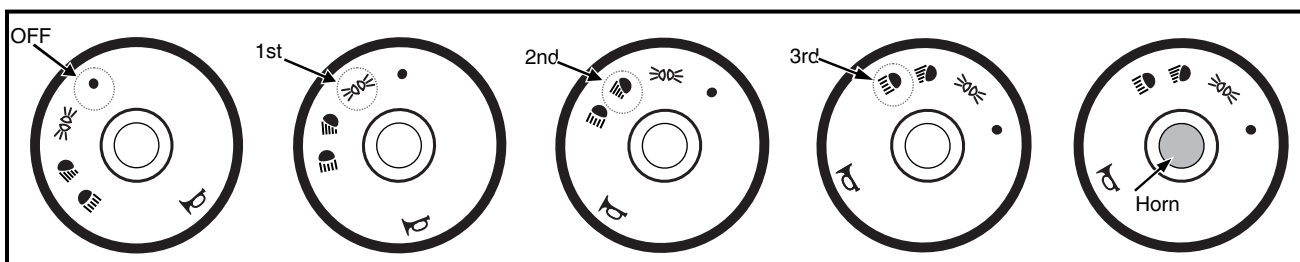

### 3.3.3 Starting Key (Ignition) Switch:

Functioning of starting key switch is as below:

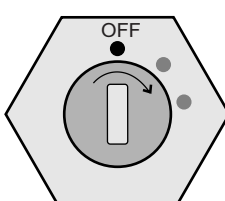
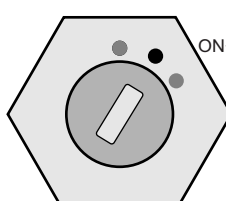
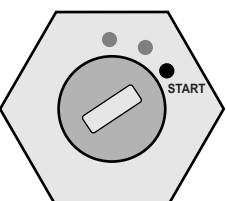
<p><b>1<sup>st</sup> Position (OFF) :</b> All the electrical systems remain disconnected in this position.</p> 	<p><b>2<sup>nd</sup> Position (ON &amp; HEATER) :</b> The warning lights (battery, oil pressure indicator) will be functional in this position. This is normal running position after the engine is started. Glow plug indication in instrument cluster will glow at this position.</p> 	<p><b>3<sup>rd</sup> Position (START):</b> Immediate after the use of air heater turn the key further clockwise to start position to start the engine.</p> 
--	---	--

- NOTE :**
- Do not keep the starter engaged more than 5-8 seconds. If engine stalls/fails to start then wait for 5-10 seconds before re-engaging the starter, otherwise you may damage it.
  - Keep the switch in OFF condition when engine is also in OFF condition.

# INSTRUMENTS & CONTROLS

## PTO ON-OFF Switch

This switch is used to ON/OFF the PTO & provide signal to PTO solenoid valve through safety controller. When the PTO switch pressed for 03 seconds the PTO will be ON. Pressing the switch again will stop the PTO and it may continue spin for sometimes in no load condition.



## Cruise ON-OFF Switch

This switch is to turn the cruise control on and off. Press in upper part of switch to activate and the lower side to deactivate cruise control.

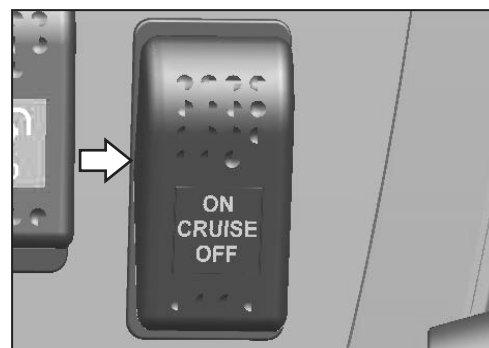

## Fuse Box

The fuse box is mounted on radiator bracket (see figure). If any electrical failure occurs, check and rectify the problem & replace the blown fuse with genuine fuse of specified rating.



Never install a wire or larger ampere fuse instead of recommended fuse.



# INSTRUMENTS & CONTROLS

## Tractor Lights - SUMMIT TX25

**Head Lights (1):** Projector lamps are provided for better focus & lighting and improve aesthetics.

**Tail Lights (2):** Tail lights are having various indications i.e. light indication for brakes and turn signal.

**Registration Plate Light (3):** Registration plate light is provided on registration plate at rear side as shown in figure.

**Work Lamp (4):** Adjustable work lamp is provided at rear side as shown in figure.

**Turn/Hazard Signal Lights (5):** These lights are fitted on ROPS as shown in figure.

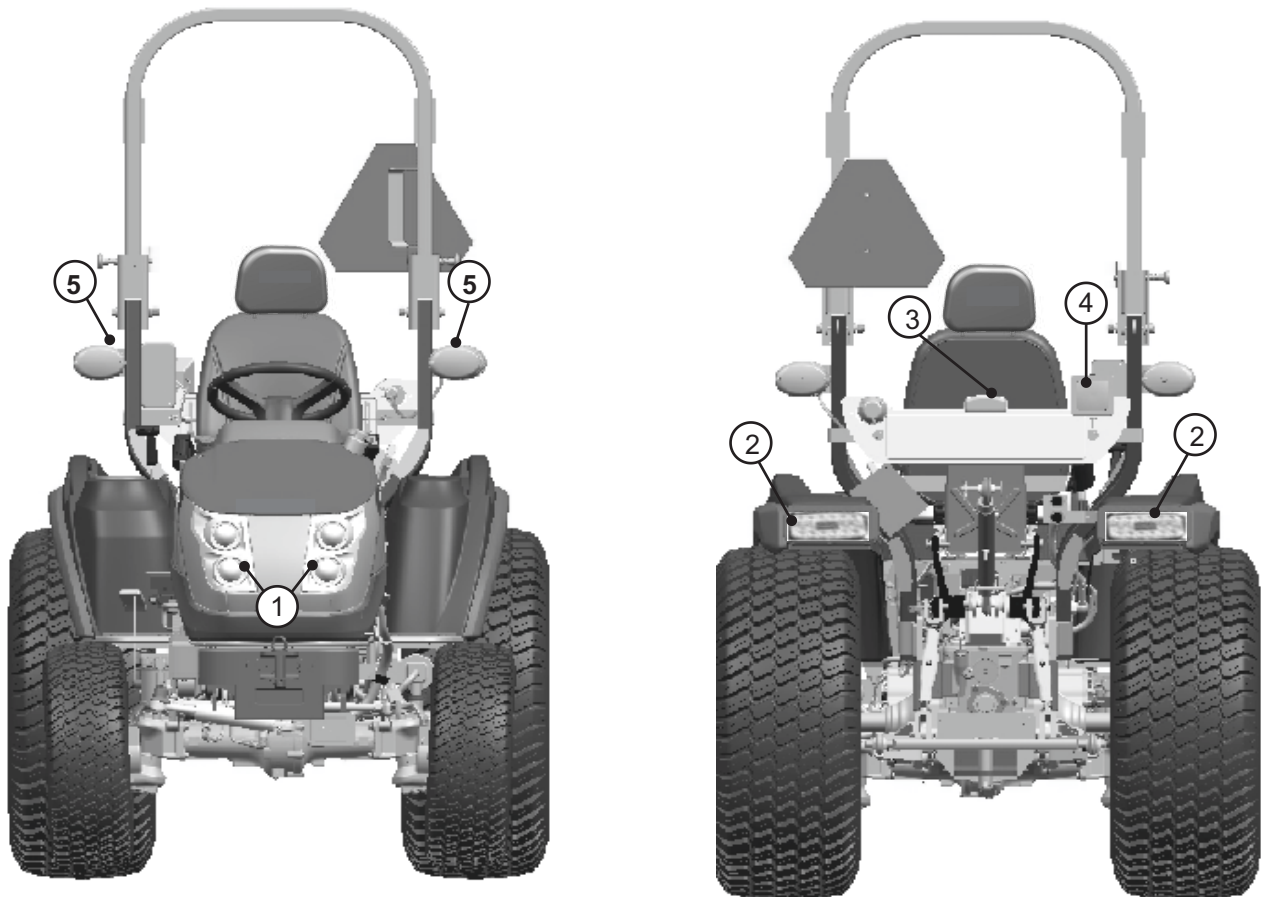

# INSTRUMENTS & CONTROLS

## Battery

Battery is located at front side of tractor on front axle bracket.  
Open the hood to access the battery.

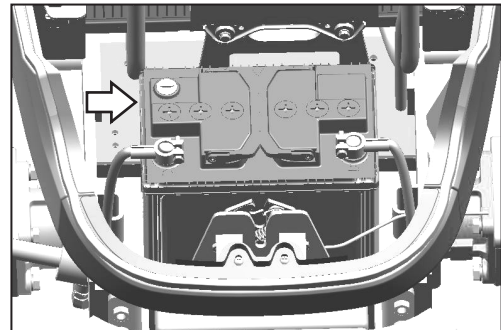

## Seven Pin Socket:

Seven pin socket mounted on licence plate to attach the trailer connections.

Details of connectors is given under:

Pin No	Used for	Wire Color
Pin 1	Left Turn Single	Yellow
Pin 2	Rear Fog light / Aux +ve	Blue
Pin 3	Ground	White
Pin 4	Right Turn Signal	Green
Pin 5	Right Parking Light	Brown
Pin 6	Brake Light	Red
Pin 7	-	-

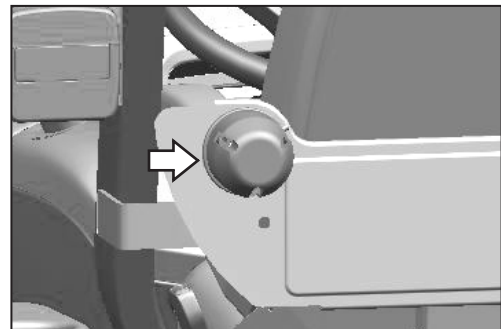

# INSTRUMENTS & CONTROLS

## Driver's Seat

While seated, adjust the weight of operator with weight adjustment knob provided at back side of seat so as to be comfortable driving & to minimize vibrations.

With the to & fro adjusting knob, slide the seat so as to have a comfortable approach towards all levers. The range of effort that can be adjusted while sitting on seat is 110.2 - 264.5 lbf [50-120 kgf]



### Horizontal Adjustment

- Lift the lever (1) to move the seat forward and backward.

### Vertical Adjustment

- Use knob (2) to adjust the suspension.
- Use knob (3) to adjust the height of the seat vertically.
- Seat belt (4) for safety.

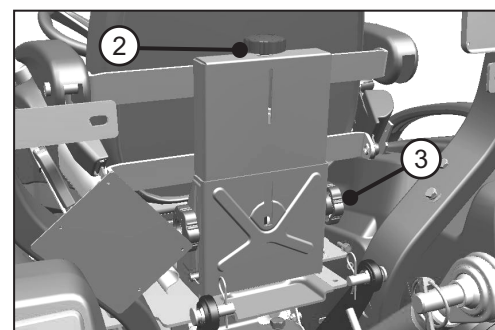

### Adjustment of Arm rest inclination:

- Raise the arm rest in upward position.
- Rotate knob (5) in clockwise direction to increase the arm rest inclination.
- Rotate knob (5) in counter-clockwise direction to decrease the arm rest inclination.

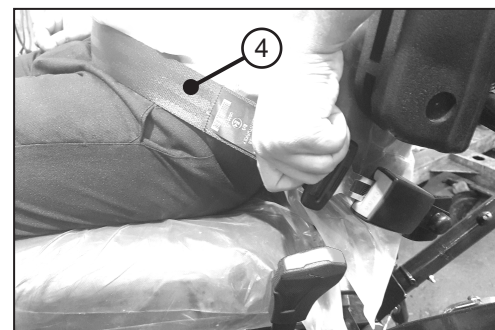

### To avoid personal injury

- Make adjustments to the seat only while the tractor is stopped.
- Make sure that the seat is completely secured after each adjustment.
- Do not allow any person other than the operator to ride on the tractor.
- Always use the seat belt when the ROPS is installed.
- Do not use the seat belt if the tractor is not equipped with ROPS.

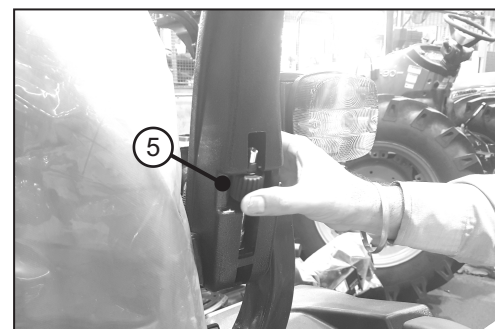

# INSTRUMENTS & CONTROLS

## Operator Seat Height Adjustment

For comfortable driving, adjust the height of the operator seat with adjustment bolt (A) and knobs (B1 and B2) provided at rear lower side of operator seat.

### Seat Height Adjustment :

- Loosen the bolt (A) from rear side knobs (B1 and B2) of operator seat.
- Remove the cap (D) from both sides knobs (B1 and B2).
- Loosen the nut (C) from both side knobs (B1 and B2).
- Loosen the knobs (B1 and B2) and set the operator seat height as per requirement then further re-tighten by rotating the knobs clock wise and counter clock-wise.
- Again tighten the bolt (A) from rear side.

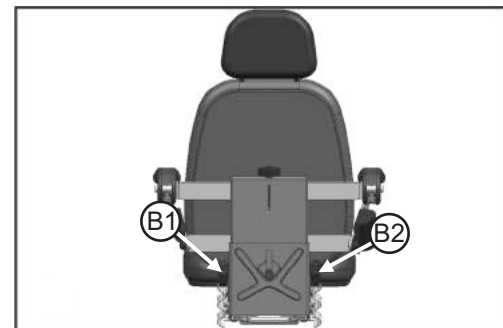
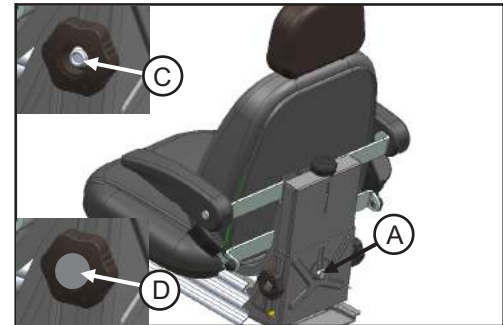

# OPERATION

## Operator Presence Control (OPC)

This tractor is equipped with an audible and visible alarm that alerts the operator when he leaves the driving position with the park brake not applied. This audible and visible alarm shall be activated after operator has been detected out of the driving position and the parking brake is not applied. The time-out of alarm is 5-7 seconds. The alarm shall be deactivated when the operator is detected to be present again in the driving position within this time period or when the parking brake is applied within this time period.

Tractor Condition	Gears Condition	Seat Condition	Parking Brake Condition	Buzzer	OPC Feedback
ON	Neutral	Operator Leaves Seat	OFF	Will Blow	Buzzer will blow continuously, engine will stop within 1 second
ON	Neutral	Operator Leaves Seat	ON	Doesn't Blow	No buzzer, no engine shut-off
ON	Engaged	Operator Leaves Seat	OFF	Will Blow	Buzzer will blow continuously, engine stops within 1 second
ON	Engaged	Operator Leaves Seat	ON	Doesn't Blow	Buzzer will not blow, engine stops within 1 second

## Boarding the Tractor

Always board the tractor from left hand side where a footrest is provided while being careful not to contact any of the levers with other parts of body. This provides easy entry for the operator.

## Leaving the Tractor

After stopping the tractor, leave the tractor from left side of tractor.

### Engine:



#### Starting the Engine:

Ignition switch is used to start the engine. Switch has following four positions. Refer below details to understand ignition switch positions in your tractor model:



- 1. OFF:** When the key is turned to this position, power supply to the electric circuits is cut off, and the key can be removed or inserted in this position.
- 2. ON:** When the key is turned in to this position, power is supplied to the electric circuits. After the engine starts, the key is held in this position.
- 3. HEAT:** This is an intermediate position between the 'ON' and 'START' position. When the key is turned to this position, the glow plugs would become hot and allow easy startup of a cold engine.
- 4. START:** When the key is turned to this final position, the starter cranks the engine and the engine starts. When the key is released, it automatically returns to the 'ON' position.

# OPERATION



## •Glow Plug

•The tractor is equipped with glow plugs. The preheating time would be determined according to the ambient temp. For details, see the table below,

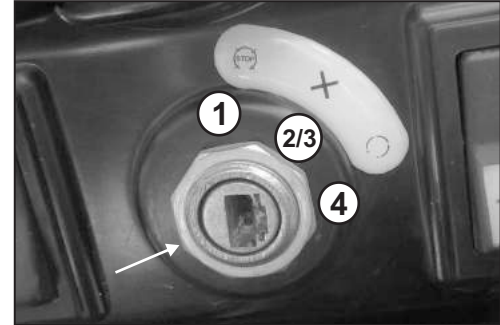
Ambient Temp (Deg F)	Ambient Temp (Deg C)	Pre-Glow time (In Seconds)	
		Min	Max
-4	-20	21	27
14	-10	13.5	18
32	0	9	12
50	10	6	9
77	25	4	6
86	30	3	5
104	40	2.5	4.5
122	50	2	4
140	60	2	4
158	70	1.5	3.5
176	80	1.5	3.5

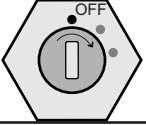
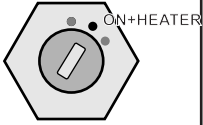

- The glow plug indicator would stay on as per above temperature conditions and will go off after the maximum time (as per above table).
- The glow plug pre-heating and functions works as per below table.

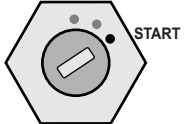
Sr. No.	Starter Switch position	Glow Plug	Glow plug Lamp on cluster	Engine	Remarks
1	1st position OFF 	OFF	OFF	OFF	
2	2nd position ON+HEATER 	ON	ON	OFF	<b>Pre Glow time:</b> This is the time to heat up the cylinder chamber for easy crank the engine. Glow plugs working depends upon the ambient temperature condition. Refer below mentioned pre glow time
3	2nd position ON+HEATER 	ON	OFF	OFF	<b>Safety switch off time:</b> If the engine is not cranked during the end of pre glow time, glow controller unit will allow glow plugs to on further for 12 sec to keep the combustion chamber in hot condition until the tractor is cranked.
4	3rd position START 	OFF	OFF	ON	Glow plugs and cluster indicator will be turn off once engine will start



# OPERATION



When the engine is running, keep as a safe distance from the radiator fan.



To prevent accidents, never allow anyone to sit on the mudguards or on any other part of the tractor or implement.

## For Starting (normal weather conditions):-

- A Engage the parking brake.
- B Check that the gear shifter lever is in neutral.
- C Move the low/ high speed selector lever to neutral position.
- D Tractor is equipped with clutch safety switch, always press the clutch pedal fully before starting the engine.
- E Check that PTO lever is in neutral.

## Cold Weather Starting

{Temperature below 32° F (0 °C)}:

### Proceed as Follows:

- A Perform operations A to E as instructed above.
- B Turn the starter key to 'heat' position and keep it there for a few seconds and then turn the key to start position.
- C If the engine fails to start repeat step 2, wait for further 5 to 10 seconds and then turn the key to start position again.

### Battery:

The battery should always be sufficiently charged. If the temp goes below 14 Deg F (upto -10 deg C), it is recommended to use below mentioned battery specifications,

- 12V, More than 700 CCA (**Length- 10.16 inch(258mm), Width-6.78 inch(172mm), Height-8.86inch(225 mm)**)

### Note:

- A If the engine fails to start after two or three attempts and smoke can be seen coming out of the exhaust, repeat the starting procedure with less time glow plug heater.

**IMPORTANT:** When outdoor temperature drops to around or below 32°F [0°C], check the cooling system and if necessary add the recommended antifreeze.

**IMPORTANT:** Do not inject fluids (ether) to make the engine easier to start in cold weather. The tractor is equipped with a cold start device.

If the engine does not start regularly and easily, do not continue as for you may run down the battery. Bleed any air that may have accumulated in the fuel system and, if the problem persists check that:

- A Fuel filters are not blocked.
- B The battery and heater plugs are working efficiently.

**Note:** Before starting a cold engine in cold weather first cover the radiator with a radiator cover. Remove the cover as soon as a normal working temperature is achieved.

## Breaking in

It is essential to take the following precautions during the breaking in period:

- A During this period, do not subject the tractor to loads greater than those it will have to deal with during the rest of its working life.
- B Engage low gears when towing heavy loads.
- C When breaking in, check regularly that all screws, nuts and bolts are tight.
- D To ensure prolonged clutch life, run in the clutch discs correctly.

## Turning off the engine:

- A Turn the engine accelerator to idle position.
- B Stop the engine by turning the starting key to 'OFF' position.

# OPERATION

## Under Hood Muffler

Under hood muffler fitted inside the hood for better aesthetics, vision and better sound muffing capabilities.

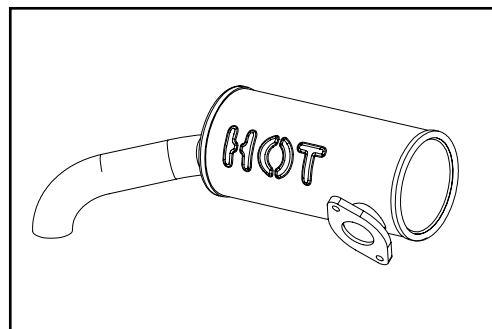

## Opening the Hood

Pull the knob (1) at front left side of the hood, till you hear a click sound, to open the hood.

Lift the hood slightly and it will automatically lift up to the preset height with the assistance of gas spring.

## Closing of Hood

Gently lower the hood down, then press until lock is engaged.

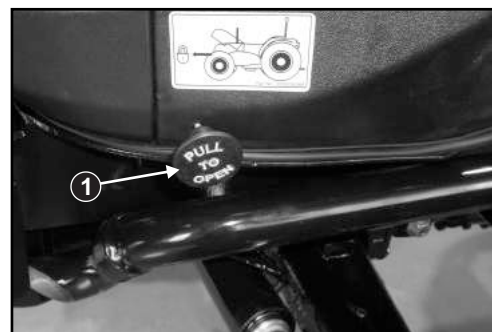

## Speed Control Pedals

There are two speed control pedals provided to drive the tractor in forward and reverse direction.

Press pedal "A" to drive the tractor in forward direction.

Press pedal "B" to drive the tractor in reverse direction.



Do not shift from forward speed to backward speed or vice versa suddenly in high range. Sudden change may damage mechanism and cause risk of injury to operator.

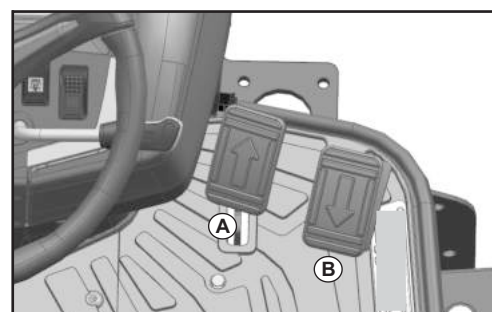

# OPERATION

## Engaging & Dis-engaging Cruise Operation - HST

The cruise control function is provided for comfort of operator. When the cruise control is engaged, the cruise control indicator on instrument panel will turn on.

### Engaging the cruise control:

- Press the forward speed control pedal till getting required speed is achieved.
- Push the cruise control switch to engage cruise control.
- Release the speed control pedal.

### Disengaging the cruise control

There are two methods to disengage the cruise control :

- Push cruise control switch "OFF"
- or
- Press the brake pedal.

**IMPORTANT:** To avoid damage of mechanism, do not press both of the speed control pedals when the cruise control is engaged.

**IMPORTANT:** Cruise operation should be disengaged while turning the tractor.

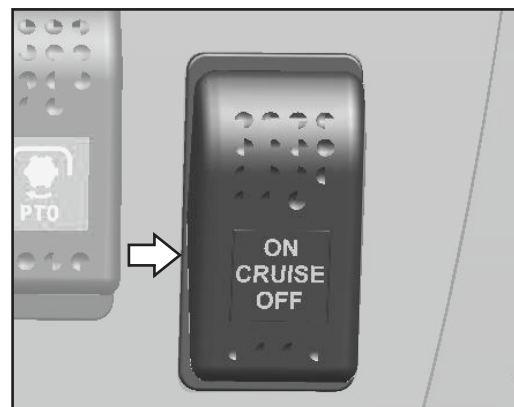

## '2WD / 4WD' Lever

You can drive the tractor in both 2WD or 4WD mode. Select the driving mode by Lever (C).

**2WD Mode:** By engaging the lever (C) in 2WD position the power is transmitted to rear wheels only. Pull the lever (C) upward to select 2WD mode.

**4WD Mode:** With the lever (C) in 4WD position the power is simultaneously transmitted to all 4 wheels (Front & Rear) of tractor. Push the lever (C) downward to select 4WD mode.

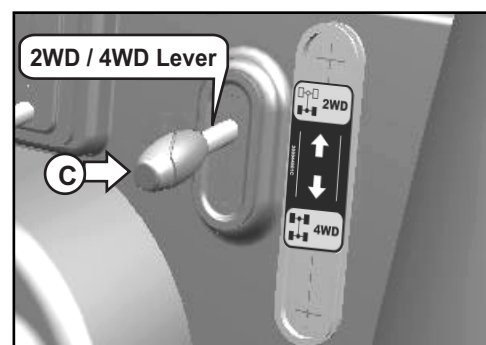

**NOTE:** 4WD Mode is for field operation and 2WD mode is for road operation.

\* 2WD=Two wheel drive

\*4WD=Four wheel drive

## OPERATION

### Hand Throttle Lever

Hand throttle lever (D) mounted on front panel is used in field application. To increase the speed of engine, push the lever up and to decrease, pull the lever down.

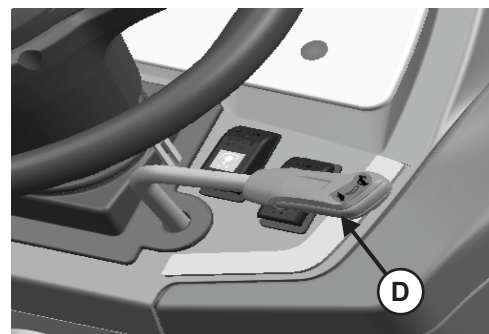

### Differential Lock

Press differential lock pedal (E) to rotate both the wheels at same speed.

**IMPORTANT:** Differential lock should only be used when traveling in a straight line. The differential lock should be disengage when turning the tractor to avoid damage to the differential assembly.

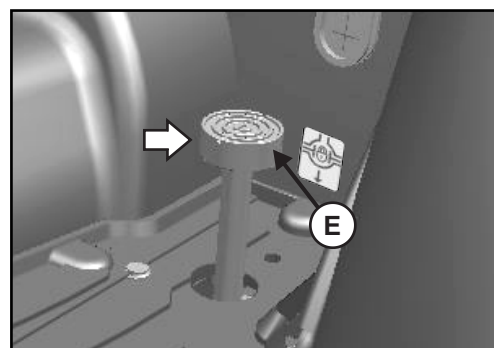

Do not apply differential lock while tractor speed is more than 3.73 mph [6 kmph] on turning.

### PTO ON-OFF Switch :

This switch is used to ON/OFF the PTO operation. This switch gives signal to PTO solenoid valve through safety controller. Press the switch for 03 seconds to engage the PTO & re-press the switch to stop the PTO.

PTO shaft may continue spin for sometimes in no load condition.

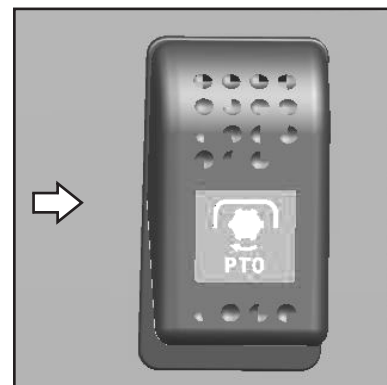

# OPERATION

## Power Take off (PTO)

Rear and mid PTO are provided for variable utility. Both can be engaged simultaneously or separately. The engine will not start if PTO switch is in ON position. The engine will shut-off if the operator leaves the seat with parking brake released and PTO engaged.

Position	Engine RPM	PTO Speed
Mid PTO	2438	2100
Rear PTO	2451	540

### Mid PTO:

Mid-PTO speed is 2100 RPM. Engage the mid PTO as per following steps:

- Decrease engine speed at idle RPM.
- Make sure that PTO switch is OFF.
- Shift PTO lever to forward direction.
- Turn on the PTO switch.
- Increase engine speed as desired.

### Both PTO:

Both mid & rear PTO will work simultaneously, engage both the PTO as per following steps :

- Decrease engine speed at idle RPM.
- Make sure that PTO switch is in OFF position.
- Shift PTO lever to backward direction.
- Turn on the PTO switch.
- Increase engine RPM as desired.

### Rear PTO:

Rear PTO speed is 540 RPM. Engage the rear PTO as per following steps:

- Decrease engine speed at idle RPM.
- Make sure that PTO switch is in OFF position.
- Shift PTO lever to backward direction.
- Turn on the PTO switch.
- Increase engine RPM as desired.

## A requirement to use only power take-off drive shafts with adequate guards



CAUTION

Remove PTO cap (A) only when the PTO is to be used. As soon as PTO-driven implement is removed, re-install cap over PTO stub shaft again afterwards. There are various versions of PTO guard that are not shown here.



CAUTION

Never operate PTO unless the master shield (B) is in the position shown. Switch off the PTO before raising the implement.

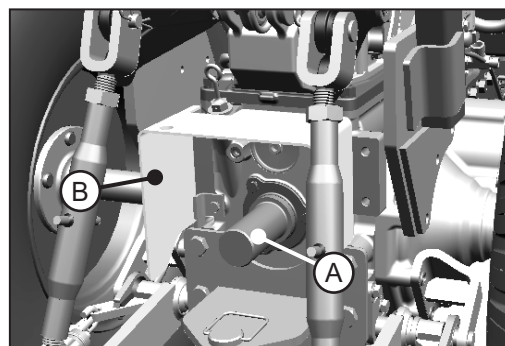
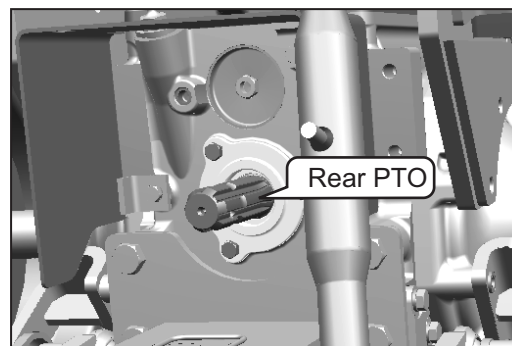
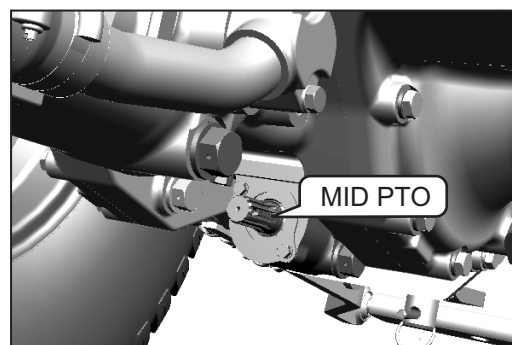
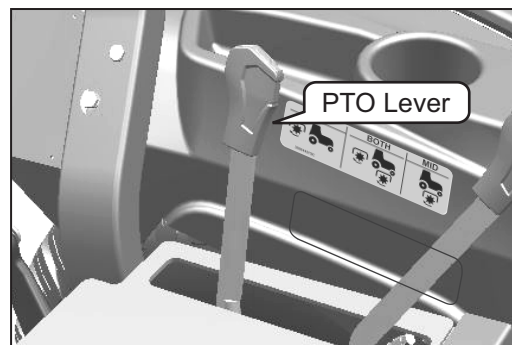

# OPERATION



Before using the PTO, the maximum permissible angle of articulation on the telescoping driveline must be ascertained. During operation, there must be no contact between the PTO guard and the telescoping driveline. This is particularly important when turning corners.



Always put a guard (B) on the telescoping driveline and take action to prevent it from turning with the shaft. Do not operate the telescoping driveline unless a guard is installed that covers the PTO shaft completely and does not turn with the shaft.



Stay clear from the area of the three-point linkage when controlling it.



The mounted machinery must be lowered on the ground before leaving the tractor.



Stay clear from the area between tractor and trailed vehicle.

## Information about using implements with power take-off drive shafts



1. Shut off engine and disengage PTO before attaching PTO-driven equipment.



High-inertia implements do not come to a stand still the moment the PTO control lever is shifted to the disengaged position. Do NOT approach the implement while it is "coasting down". Do not work on the implement until it has stopped.



Before attempting to clean, adjust or lubricate a PTO-driven machine, three-point linkage, always make sure the PTO is switched off and stopped, the tractor engine is shut off and the ignition key is removed.

Turn key off to stop engine.

- Attach implement to tractor before connecting PTO drive line. Lock three-point linkage in upward position if it is not to be used.
- Rotate PTO shield upward for clearance. With engine off, turn shaft slightly by hand if necessary to line up splines. Connect drive line to PTO shaft. Pull out on shaft to be sure drive line is locked to PTO shaft. Place PTO shield in downward position.
- Be sure all shields are in place and in good condition. Never operate PTO unless master shield is properly installed. With engine stopped, check integral shields on drive line by making sure they rotate freely on shaft. Lubricate or repair as necessary.
- Check carefully for any interference, make sure three-point linkage is locked in the upward position if it is not used.



**Warning: Do not open or remove safety shield when engine is running.**



**Warning: Stay Clear of rotating machine parts.**

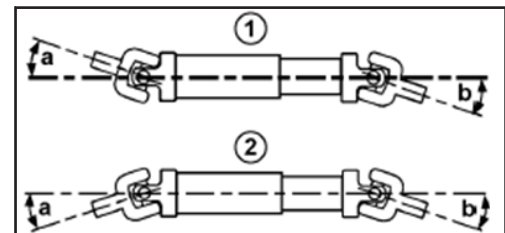

Articulation on Telescoping Driveline

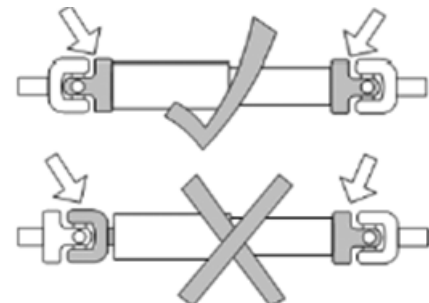

Align Forks Correctly  
1 - Z-shaped layout  
2 - W-shaped layout



# OPERATION

As far as possible, angles (a) and (b) at the universal joints should be the same at both ends of the telescoping drive line.

In applications where this is not the case (e.g. sharp turns with PTO engaged), it is recommended to use a continuous-velocity drive shaft.

**NOTE:** The two schematic drawings do not show any guards on the telescoping drive line. A guard is mandatory when using telescoping drive lines.

**IMPORTANT:** Only operating conditions described in the operator's manuals of the various implements are permitted. This applies particularly to maximum permissible angle of articulation, to the use of freewheel clutches and overload clutches, and to the prescribed amount of overlap when

engaging pipes are pushed together.

**IMPORTANT:** Before using a PTO-driven implement, take action to ensure that the telescoping drive line is lubricated regularly. Comply with instructions in the operator's manual provided by the manufacturer.

**IMPORTANT:** On multi-component telescoping drive lines, the yokes at each end must be aligned as shown. The yokes at each end must not be at 90° to one another.

## PTO drive shaft

**IMPORTANT:** PTO transmission system has no one way clutch. With implements rotating in high speeds such as rotary mower & leaf blower, be sure to select and use a drive shaft with one way clutch.

Before attaching PTO drive shaft to tractor and implement, be sure to check and adjust the drive shaft length to avoid transmission damage.

Minimum overlap at fully extended: 3.9 inch(100 mm).

If the length of drive shaft is too short, it causes damage to the PTO shaft and transmission of tractor and/or implement by slipping out the drive shaft when lowering the implement.

Minimum clearance to the female shaft end at fully retracted position should be 1 inch(25 mm).

If the length of drive shaft is too long, it causes damage to the PTO shaft and transmission of tractor and/or implement when lifting the implement.

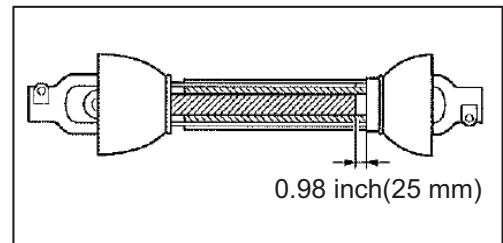
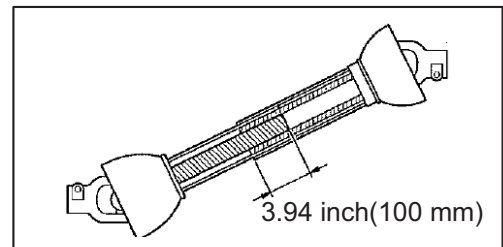
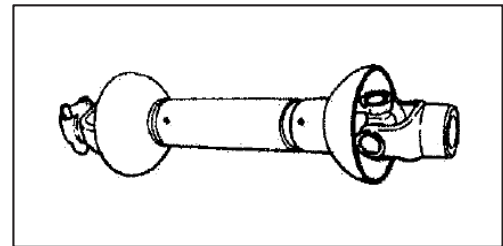

# OPERATION

## Hydraulic Coupling Devices

One double acting (1DA) with detent type and kick off direction control valve (DCV) is equipped as a standard fitment in your tractor. The DCV is used when attaching the implement operated by hydraulic cylinder.

The female Quick Release Couplers (QRC's) are located at rear side of tractor.

1. Make sure hose end and coupler receptacles (male & female) are in perfectly clean condition.
2. Remove dust plug from QRC's.
3. To connect male coupler, push it firmly into female coupler receptacle. Pull lightly to make sure positive connection was made.
4. Use DCV lever for operating DCV.
5. Move the DCV lever forward or backward to control the implement.

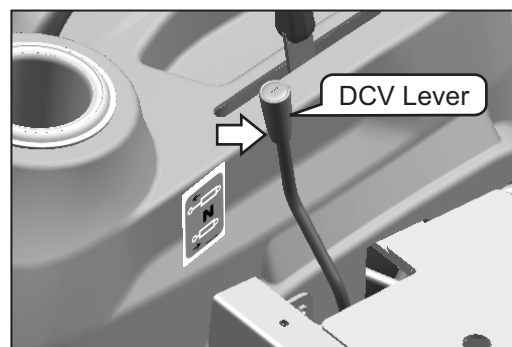
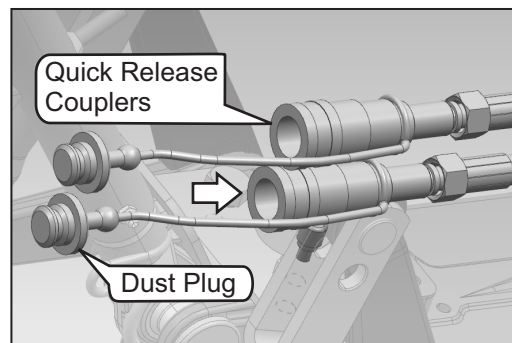

## Power Steering

The tractor is equipped with power steering with a pump of 6.7 CC & steering unit of 40 CC which enables the operator for ease in steering operation.

**NOTE:** The power steering function goes off when the engine is shut-off.

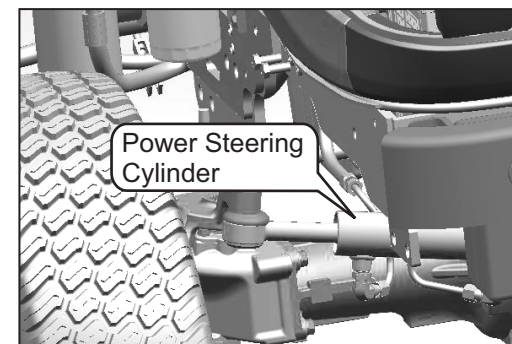

## Transport Lock (Response Valve)

It acts as safety device during transportation of implements. It is located on front end side of hydraulic rear cover below driver seat.

**Use:** While implements transportation, lift the implement at desired height and then fully tighten the response valve to close it.

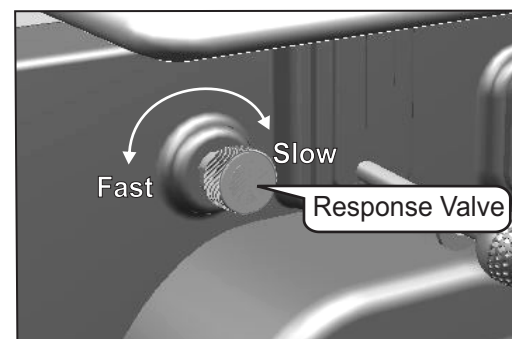

Response valve should always be closed during implements transportation.



# OPERATION

## Hi-Low Lever

This lever is used to change the low speed into high speed or vice versa when tractor is moving. It is used in combination with the main shift lever to set the tractors travel speed.

### Speed Selection:

1. Neutral Position: Lever in the middle notch.
2. High Speed: Move the lever out of the notch and shift the lever towards the back of the tractor.
3. Slow Speed: Move the lever out of notch and shift the lever towards the front of the tractor.

Note: Select the speed after starting tractor as required.

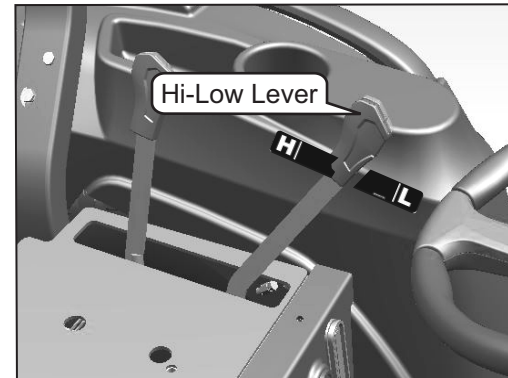

## Service Brake

The service brake pedal located to left hand side of the platform.

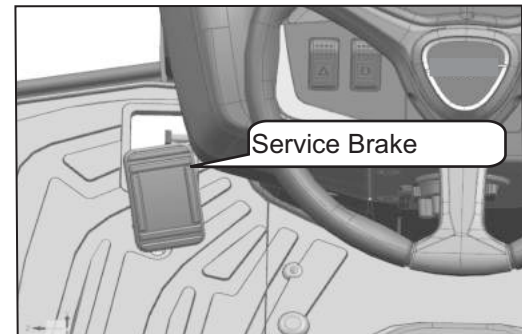

## Parking Brake

The parking brake is located below operator's seat and engaged by the parking brake lever which acts on the brake discs by means of a mechanical control.

### Parking brake engagement

- Pull the parking brake lever upward to operate the parking brake.

### Parking brake disengagement

- Press sleeve (A) in forward direction, push the parking brake lever downward and release the sleeve 'A'.

*Always engage the parking brake when the tractor is used for work at a standstill, even if only for brief periods of time.*

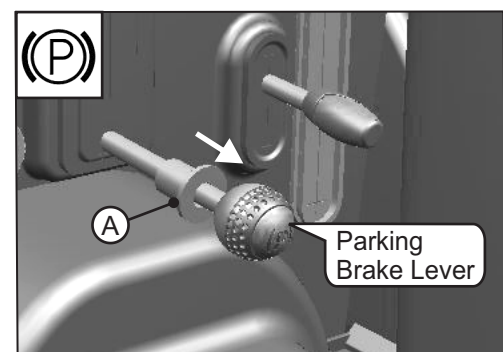

**IMPORTANT :** Driving the tractor with the parking brake partially engaged will cause damage to internal brake components.



*Always engage the hand brake when the tractor is used for work at a standstill, even if only for brief periods of time.*

# OPERATION

## Wheels and Tires

Recommended Tire Pressure : Front: **20~22 P.S.I** / Rear: **14~16 P.S.I**

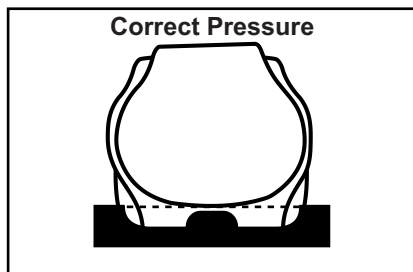

- Good adherence by dirt grousers.
- Good cleaning of the tread

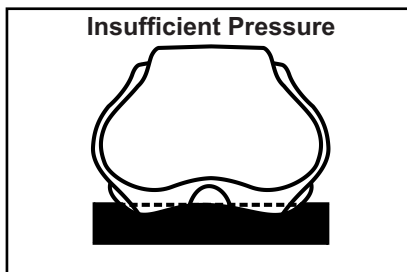

- Reduce adherence through lack of tire grip.
- Deterioration of tire casing by traction forces.

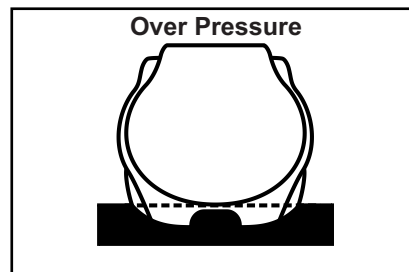

- Reduce grip due to lack of cleaning
- Deterioration due to compacted ground.

## Check Torque of Front and Rear Wheel Hardware

Check the torque of the front wheel rim (A) and rear wheel rim (B), tighten to the specifications:

Front wheel rim: 53 lbf-ft [72 Nm]

Rear wheel rim: 103 lbf-ft [130 Nm]

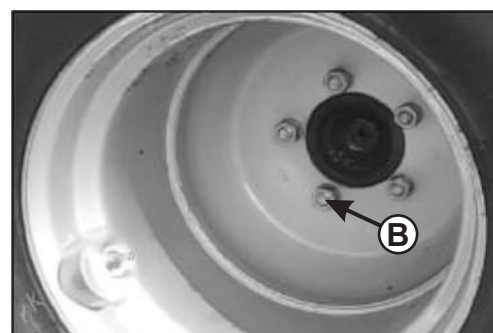
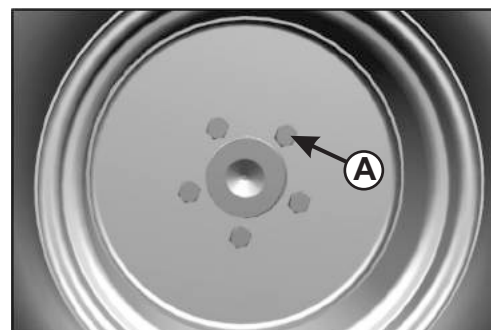

# OPERATION



## Wheels and Tires

Tires play vital role in transportation and agriculture operations. It is the most important factor in the efficient performance of tractor it should be used only as per company recommendation. Here we will discuss only pneumatic tires.

On any tire there is some marking which represents its size & capacity e.g. tire marking is 8.3x20, 4 ply rating i.e. 8.3 inch is the section width, 20 inch is the bead diameter. Ply rating doesn't show that the same no. of plies are inserted in tire. It is only comparative measure of the load carrying capacity (L.C.C) of tire. As more ply rating shows more L.C.C. at the same time as L.C.C. increase the shocks absorption capacity decreases.

In general, tractor is considered for two types of work:

- Work on soft soil where maximum adhesion is needed. In this case there will be use of lowest pressure compatible with the load carried.
- Work on hard ground and roads, towing etc. In this case there will be use of maximum pressure.

## Load Carrying Capacity

Tire Combination	Axle	Tire Dimensions including load capacity index and speed category symbol	Tire Load rating per tire pound(Kg)	Max. permissible vertical load on coupling point pound(Kg)
1	Front	Goodyear R14 23x8.50-12	1230(560)	546.75(248)
	Rear	Goodyear R14 12-16.5	2760(1250)	
2	Front	6.00-12 & 76 A6	881.85(400)	
	Rear	8.3-20 6PR & 96 A6	1543.24(710)	
3	Front	7-14 8 PR & 72 A6	1510.17(685)	
	Rear	8.3-24 & FARM 2000 8PR	2061.32(935)	
4	Front	6.5/80-12 & 80 A6	1433(650)	
	Rear	280/70 R18 & 114 A8	2601.46(1180)	
5	Front	23x8.5-12 & LG 306 TL	2116.44(960)	
	Rear	33x15.5-16.5 & LG 306 TL	3637.63(1650)	
6	Front	25x8.50-14 (Lg306)	1653.47(750)	
	Rear	13.6x6 (Lg306)	2094.39(950)	
7	Front	23x8.5-12 12 PR SPHD	1851.88(840)	
	Rear	33x15.5-16.5 12 PR SPHD	4299.02(1950)	

# OPERATION

## Three Point Linkage

Three-point linkage is used to mount the implement, which is fully mounted, or semi-mounted and used for different field operation. Three-point linkage is controlled by hydraulic lever. In this two lower link are available, of which one side of the lower link is attached with differential housing and other is used to hitch the lower pin of the implement. Lift rods are mounted on lift arm that is operated through rock shaft. Loose side of top link is used for attaching upper hitch pin of implement. Top link is adjustable for proper setting of implement and for easy connection of implements.

### Adjustable Lift Rods

The lift rods can be adjusted mechanically or hydraulically, depending on the lifting, to make the lower links level and lined up with each other. This will depend on the type of implement being used and the work to be done.

### Top Link

For length adjustment of top link, fix the top link other end and turn the lever for increasing or decreasing the length. During field operation lock the tube to avoid unnecessary turning.

### Lower Links

Lower links are provided for hitching the implement.

### Attaching Implement to Three Point Linkage

Position the tractor to align corresponding linkage with the hitch points of implements. Keep the implement on hard & leveled surface and attach as per given below instructions :

- First attach with left lower link and right lower link.
- Then at last attach with top link.

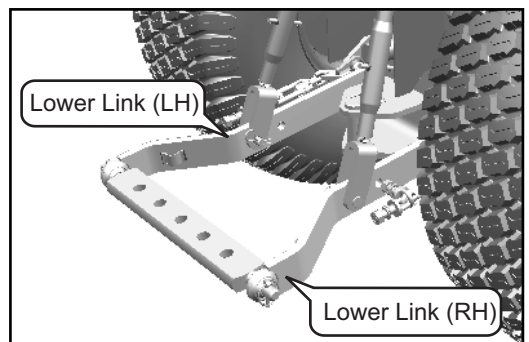
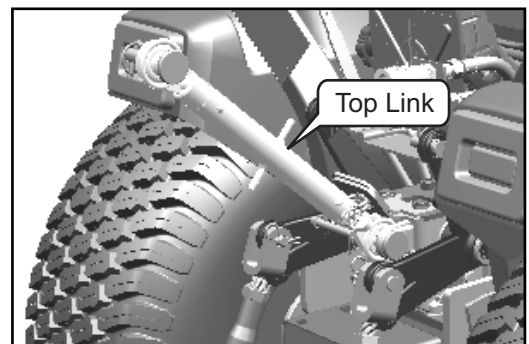
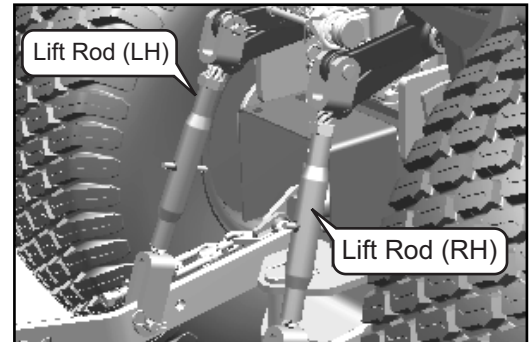
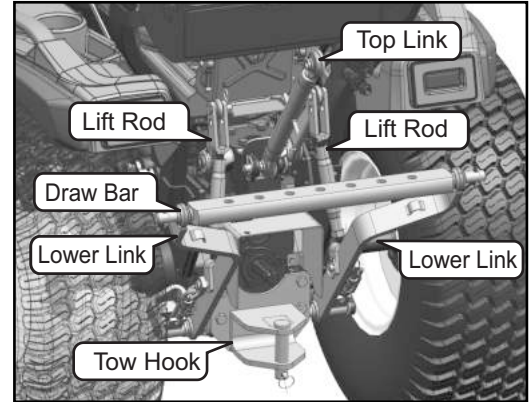

*Stay clear from the area of three point linkages while attachment and detachment of implements.*

**NOTE:** Maximum lifting capacity of three point linkage at 24" from lower link ends, is 661.39 lb(300 kgf).

# OPERATION

## Hydraulic System

In your tractor, live hydraulic system is provided in which hydraulic pump is driven by engine and mounted at cover of engine. As the engine runs, the hydraulic pump also starts working and the oil is transferred from pump to lift via priority valve (located at LH side of Engine). Transmission lubrication oil is used as hydraulic oil.

### Position Control Lever (1)

This orange color lever is mounted on R.H.S. of driver seat which enables raising or lowering the implement/lift.

### Priority Valve

Priority valve gets oil input from hydraulic system and serves as a unit to provide oil to:

1. Steering Mechanism
2. Hydraulic Lift
3. Rear remote unit

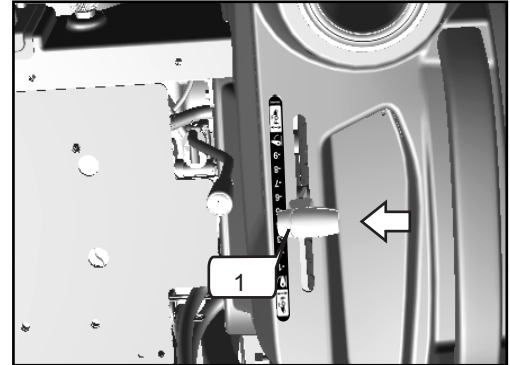

## OPERATION

### Safety Frame: Roll Over Protection Structure (ROPS)

A safety frame and seat belt is fitted as standard equipment to the platform tractor at the time of factory assembly. If the safety frame was deleted by the original purchaser or has been removed, it is recommended that you equip your tractor with a safety frame and a seat belt. Safety frames are effective in reducing injuries during overturn accidents.



**WARNING** : A tractor overturning without safety frame can result in serious injury or death.

#### Operation:

- ! Before using the tractor ensure that the safety frame is not damaged, that it is securely fastened to the tractor.
- ! If the safety frame has been removed from the tractor, it must be refitted or erected immediately using the proper hardware and applying the recommended torque value.
- ! DO NOT ATTACH chains, ropes or cables to the safety frame for pulling purposes; this will cause the tractor to tip backwards. Always pull from the tractor drawbar.
- ! Always wear your seat belt-adjusted snugly except when the safety frame has been removed.
- ! Check the seat belt for damage. A damaged seat belt must be replaced.

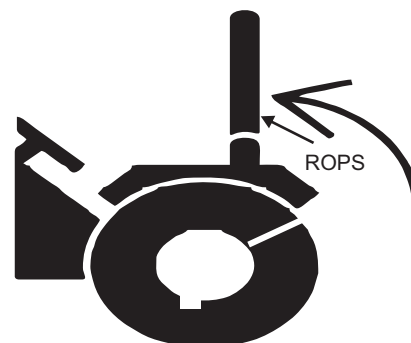

To avoid personal injury hold the ROPS tightly with both hands and fold the ROPS slowly and carefully.



When raising or folding the ROPS, apply parking brake, stop the engine and remove the key. Always perform function from a stable position at the rear of tractor. Fold the ROPS down only when absolutely necessary and fold it up and lock it again as soon as possible.

# OPERATION

## Normal Operating Position-

For normal operation, including transport, always use the ROPS in the upright position with a fastened seat belt for full rollover protection.



## Operating Foldable ROPS-

Following procedure is folding the ROPS

1. Remove R-pin (1) from pin(2) and then remove pin (2) from ROPS frame.
2. Turn the ROPS towards backward until rest on stopper.
3. Install the pin with the R-Pin on down position.

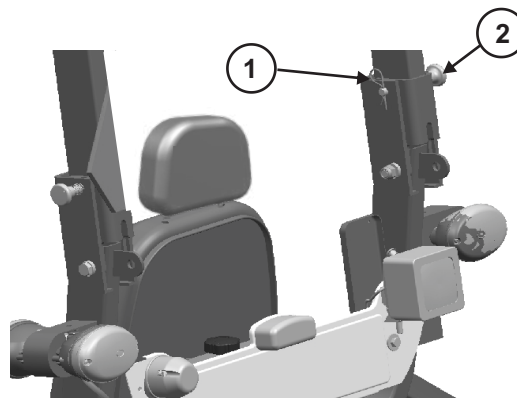

# MAINTENANCE



## Maintenance Schedule

Observe the following maintenance schedule. This maintenance schedule is applied to tractors which are operated under normal conditions. When your tractor is frequently operated in muddy places, greasing must be carried out more frequently and when the tractor is often operated in dusty places, clean the air cleaner element and fuel filter more frequently. Extra servicing must be carried out according to particular situation.

Parameters	50 Hours	Every 250 Hours	Every 500 Hours	Every 750 Hours	Every 1000 Hours	Every 1250 Hours	Every 1500 Hours
<b>General</b>							
Washing	W	W	W	W	W	W	W
Greasing	G	G	G	G	G	G	G
Re-tighten All Fasteners	CT	CT	CT	CT	CT	CT	CT
Rear View Mirror Holder	CT	CT	CT	CT	CT	CT	CT
<b>Engine</b>							
Engine Oil	R	R	R	R	R	R	R
Engine Oil Filter	R	R	R	R	R	R	R
Tappet Clearance	CA	CA	CA	CA	CA	CA	CA
Fuel Filter Element	R	R	R	R	R	R	R
Fan Belt Tension	CT	CT	CT	CT	CT	CT	CT
Radiator Coolant Level	CP	CP	CP	CP	CP	CP	CP
Coolant Change/Radiator Flushing	At every 1000 hours or 2 Years, whichever is earlier						
Air Cleaner Element	CL	CL	CL	R	CL	CL	R
Fuel Injector	Nozzle tip cleaning at every 1500 hours or whenever required Fuel injection nozzle at every 3000 hours or whenever required.						
Glow Plugs	-	-	C	-	C	-	C
Fuel Tank Cleaning	At every 500 hours or 1 Year, whichever is earlier						
<b>Transmission / Hydraulic</b>							
Transmission Breather Assy	CL	CL	CL	CL	CL	CL	CL
Hydraulic Oil Filter (Suction)	R	R	R	R	R	R	R
Hydraulic Oil Filter (Delivery)	R	R	R	R	R	R	R
Transmission Oil	R	R	R	R	R	R	R



# MAINTENANCE

Parameters	50 hrs	Every 250 hrs	Every 500 hrs	Every 750 hrs	Every 1000 hrs	Every 1250 hrs	Every 1500 hrs
Operation of Hydraulic Lift	C	C	C	C	C	C	C
Hydraulic Oil Strainer	CL	CL	CL	R	CL	CL	R
<b>Brakes</b>							
Operation of Brakes	C	C	C	C	C	C	C
Brake Pedal Free Play	CA	CA	CA	CA	CA	CA	CA
<b>Steering</b>							
Steering Operation	C	C	C	C	C	C	C
<b>Front Axle 4x4</b>							
Front Axle Differential Oil	R	C	R	C	R	C	R
Breather Assy	CL	CL	CL	CL	CL	CL	CL
Front Axle Pivot	C	C	CA	C	CA	C	CA
<b>Wheels and Tires</b>							
Front Wheel Bolts	CT	CT	CT	CT	CT	CT	CT
Rear Wheel Nuts	CT	CT	CT	CT	CT	CT	CT
Tire Inflation Pressure	CA	CA	CA	CA	CA	CA	CA
<b>Battery</b>							
Battery Electrolyte Level	C	C	C	C	C	C	C
Battery Terminals	CL	CL	CL	CL	CL	CL	CL
<b>Electrical</b>							
Functioning of All Gauges & Meters	C	C	C	C	C	C	C
Functioning of Alternator & Starter	C	C	C	C	C	C	C



*Safety Starter Switch is to be replaced after every 2000 hours or 4 years, whichever is earlier.*

**C**-Check, **CA**-Check & Adjust, **CL**-Clean, **CP**-Check & Fill, **CR**-Clean & Replace, **CT**-Check & Tighten, **R**-Replace, **W**- Washing. Beyond 1500 hours, repeat the cycle every 250 hours.

## IMPORTANT:

- Engine oil grade should be selected as per operating temperature condition.
- Antifreeze should be used in sub zero ambient temperature.
- Clean air cleaner system as and when required as per field operating conditions.
- Clutch pedal play should be adjusted as per field operating conditions.

# MAINTENANCE

## Fuel Tank Filling



*Comply with the following instructions when working with the diesel fuel:*

1. Do not smoke while filling the fuel tank because diesel is flammable liquid and can catch fire easily.
2. Mixtures of diesel fuel and alcohol are not approved since the resulting lubrication of the fuel injection system is insufficient.
3. Clean the area around the filler neck where the fuel is poured.
4. Fill the tank at the end of the day to prevent the formation of overnight condensation.
5. Never remove the plug or fuel the tractor while the engine is running. Keep control of the pump nozzle whilst the tank is being filled.
6. The tank must not be completely filled. Allow space for an increase in volume. If the original fuel cap is lost, it must be replaced with an original spare which must be fully tightened.
7. Dry up any fuel spill immediately.

## Fuel Requirements

It is important to use good quality fuel for the long life & good performance of the engine. The fuels must be clean, well refined and non-corrosive for the fuel system components. Make sure that you use fuel of a known quality and reliable origin.

## Fueling

Before you fuel the tractor, clean the zone around the filler neck to prevent foreign bodies from entering the tank. After fuelling, tighten the plug properly.

## Fuel Storage

Take all the necessary precautions to ensure that stored fuel does not become polluted with dirt, water or other substances.

Store fuel in cans. Do not store it in galvanized cans as the galvanization treatment would react with the fuel and form compounds that would spoil the injection pump and injectors.

- Store fuel cans away from direct sunlight and slightly tilted, so that any sediment inside is eliminated through the outlet tube.
- To make sludge and water condensation easier to remove; there should be a discharge plug (c), in the lowest point, on the opposite side to the drain tube.
- If the fuel is not filtered from the storage can, use a funnel with the fine gauge mesh over the fuel tank neck when fueling.
- Plan your fuel purchases so that summer fuels are not kept for too long and used in the winter.

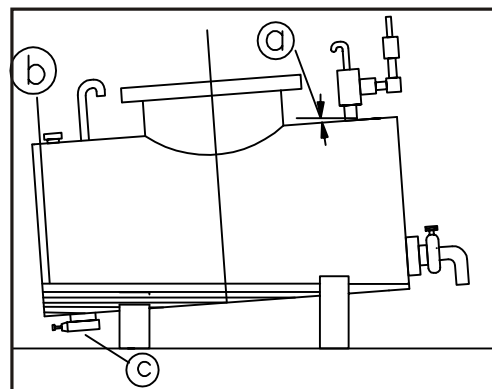

Setting up a tank for fuel storage and decanting.

- a. Slope 25%.
- b. Condensation water.
- c. Sludge drain plug.



Fuel Tank Cap

# MAINTENANCE

## Replacement of Fuel Filter

1. Shut down petcock.
2. Remove the filter by rotating it in counter-clockwise direction by hand or special wrench.
3. Take new filter and check it for proper seating of gasket.
4. Apply clean engine oil to gasket on the new fuel filter.
5. Install fuel filter, when the filter gasket contacts the mounting surface of filter, tighten the filter and ensure that there is no leakage.

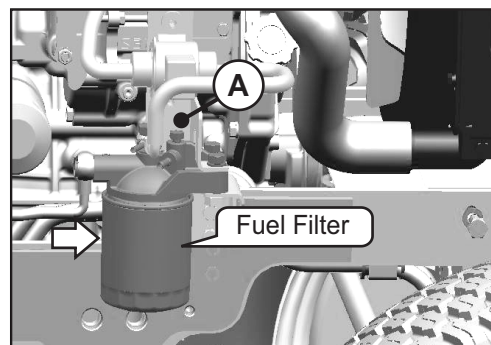

## Air Bleeding of Fuel System

After changing the fuel filter, air must be removed from the system:

1. Switch ON the ignition key to start the electric pump until completion of air bleeding process.
2. Loosen the vent plug (A) at top of fuel filter body.
3. Tighten the vent plug (A) after bubble free fuel flows from the air vent plug hole.
4. Loosen the vent plug (B) of FIP and allow the air to flow out from the system.
5. Tighten the vent plug (B) after bubble free fuel flows from the return valve.

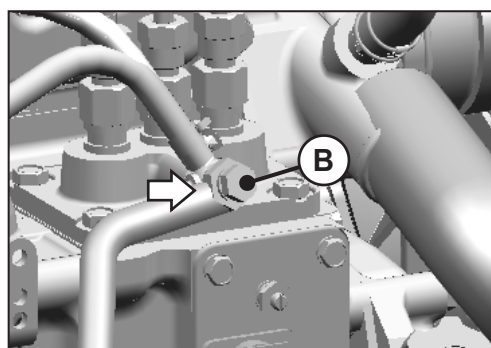

## Radiator

### Checking Coolant Level in Radiator

Slowly open the radiator cap (1) up to the safety catch (about 1/3 turn). Wait to allow the steam to escape. Continue opening the cap, press it down firmly to release the safety catch. The level of coolant should just touch the tab located in the filling spout.

If the level has dropped, check the entire cooling system for leakage (radiator, hoses etc.) If there is no leakage, top up the coolant up to the maximum mark.

Fill the reserve tank (2) with coolant up to the full line mark for coolant top up.

Coolant is a mixture of water and anti rusting / anti freezing agent in a recommended ratio.

**In sub zero temperature climate conditions use Glysantin G40 antifreeze agent along with water in following ratio:**

Temperature Range °F [°C]	32 to 26.6 [0 to -3]	26.6 to 17.6 [-3 to -8]	17.6 to 3.2 [-8 to -16]	-16 to -25 [-13 to -13]	-13 to -34.6 [-25 to -37]	-34.6 to -67 [-37 to -55]
Antifreeze (%)	10	20	30	40	50	60

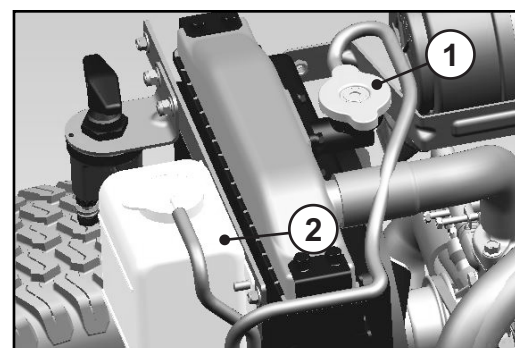

# MAINTENANCE

## Checking Engine Oil Level

Before checking the oil level be ensure that tractor is parked on leveled ground. Stop the engine and wait for some time, as all oil should return to oil sump.

Check the oil level by unscrewing dipstick (located at RHS of the Engine). Top up the oil level if the level is below the minimum level mark. Do not over fill than maximum level mark. Oil level should be between maximum and minimum marks .

Recommended grade & oil capacity of engine oil is listed at the end of this chapter.

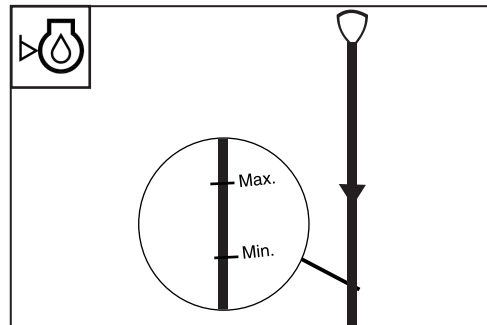

Dipstick marks

## Replacement of Oil Filter & Engine Oil

### Changing Oil Filter:

1. Stop your tractor to the side of road on leveled surface and drain the engine oil in an oil pan after removing the drain plug.
2. Remove the oil filter by rotating it in anti-clockwise direction by hand or with the filter wrench.
3. Take new oil filter and check it for proper seating of gasket.
4. Apply clean engine oil to gasket on the new oil filter.
5. Install oil filter. When the filter gasket contacts the mounting surface of filter, tighten the new oil filter.

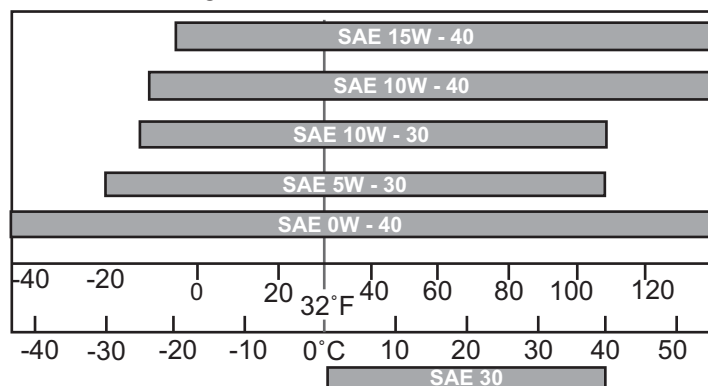
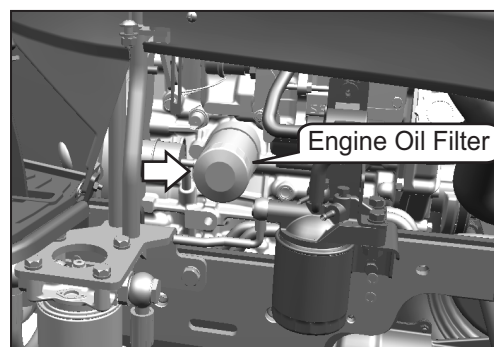

### Refilling Engine Oil :

1. Re-install the drain plug and remove the oil filler cap .
2. Fill the engine oil with the specified engine oil to the specified level to sump capacity from oil filler cap.
3. Insert into the oil level gauge guide, then pull out the gauge again.
4. Ensure that oil level should be between the max. & min. marks on the dipstick. If less, then pour the oil to bring it to specified level.
5. Install the oil filler cap after a refill.
6. Check the oil pan and other parts for oil leakage.
7. Start the engine, allow it to run idle and don't race it immediately.

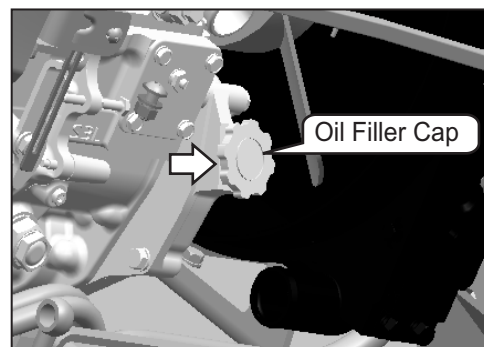

# MAINTENANCE

## Radiator Draining & Flushing (When cold)

1. Remove the radiator cap and drain plug .
2. Let the coolant drain out. Close petcock and plugs. Flush the cooling system with water / cleaning solution for 15 minutes, then drain the cleaning solution.
3. Refit the drain plug and refill the coolant (mixture of water, anti scaling agent, antifreeze).
4. Run the engine with radiator cap open and accelerate 2-3 times and Top up coolant if required.
5. Refit the radiator cap and ensure tightness all the connections for any leakage.

**Note:** Coolant can be maintained in the circuit for 2 years or 1000 hours of operation, whichever is earlier. After this period mixture must be changed.

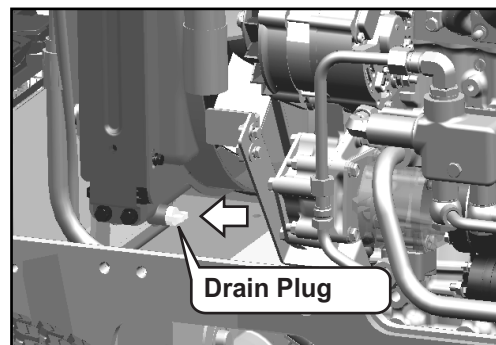

## Radiator Fins Cleaning

1. Check radiator fins for holes or cracks for blockage.
2. To clean the radiator blow compressed air from engine side to outside.

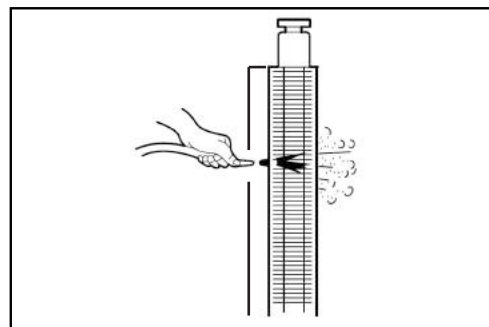

## Radiator Cap

Cooling system is closed pressurized system so don't operate the tractor without radiator cap or cap with damaged rubber seals/defective release valve to avoid water loss and engine overheating.

Use genuine radiator cap only.

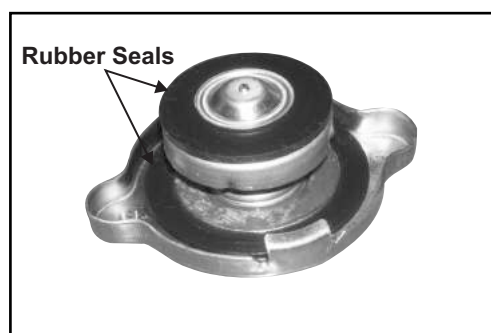

## Inspection of Hoses

### Check/Replace Hoses

- Check hoses regularly – on every service/before cranking tractor after long idle standing– for leaks, kinks, cuts, tears, rubbing, bulges, corrosion, exposed fabric and other signs of wear and damage.
- Replace worn or damaged hoses immediately.
- Replacement hoses are available from your authorized servicing dealer.



**NOTE:** Refer maintenance schedule for inspection interval of hoses.

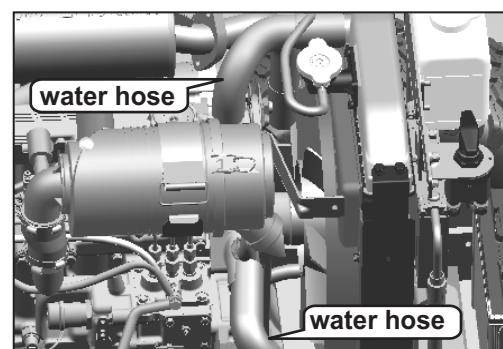

# MAINTENANCE

## Air Cleaner Maintenance

### Air Cleaner Components

- (1) Air Filter Housing
- (2) Clamp
- (3) Cover
- (4) Rubber Valve
- (5) Air Cleaner Element
- (6) Clogging Sensor

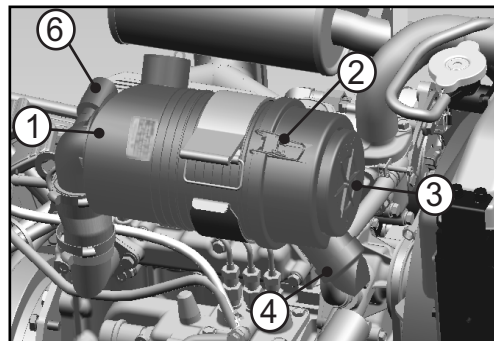

Discharge the dust deposits and sediments daily by pressing the rubber valve (4) on the air filter housing (1).

### Important Instructions :

- Clean the air cleaner element at first 50 hrs & then after every 250 hrs of operation or whenever the clogged filter indicator light on the dashboard is illuminated.
- Clean filter element by blowing air from inside. Maximum pressure should not exceed 23 P.S.I(1.6 bar).
- Use clean cloth to wipe sealing areas of element.
- After replacing new filter element ensure matching of (◀) mark on cover with the mark (▶) on air filter housing.
- Ensure proper seating of filter into housing before latching the cover. Do not use latches on the cover to force the filter into air cleaner that could cause damage to housing and will void the warranty.
- Ensure proper seating of all rubber rings. Replace the damaged ones.

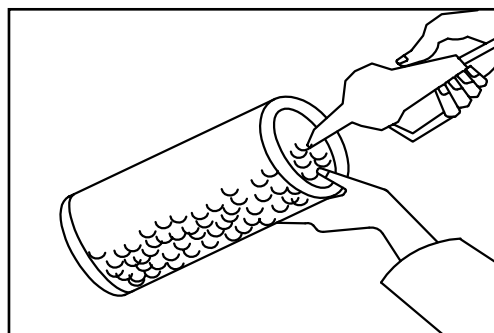
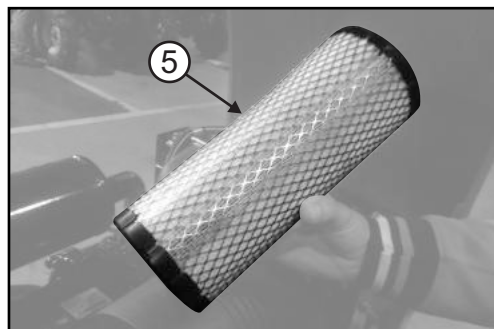

**Replace air cleaner element after three cleaning operations or at every 750 hours, whichever is earlier.**

**IMPORTANT:** NEVER attempt to clean the filter element with exhaust gas from the engine. NEVER ever use oil on dry filter. NEVER ever use oil, diesel fuel, paraffin or solvents to clean the filter element.



# MAINTENANCE

## Brake Pedal

Brake pedal is located at the left side of the platform. Tractor motion is controlled by gradually pressing the brake pedal as per requirement.

## Brake Free Play Adjustment

Press down the brake pedal until you feel the restriction and measure the free play of pedal as shown in the figure. The distance should be 0.98 inch to 1.18 inch [25 to 30 mm]. If the distance is less than 0.98 inch [25 mm] or higher than 1.18 inch [30 mm] then get it adjusted.

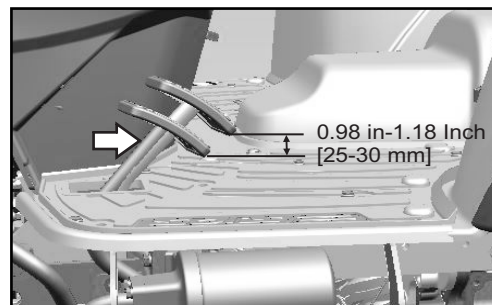

## Steering Cylinder Knuckle Joints

Have the knuckle joint nuts checked by an authorized service center after the first 50 hours and then at every service.

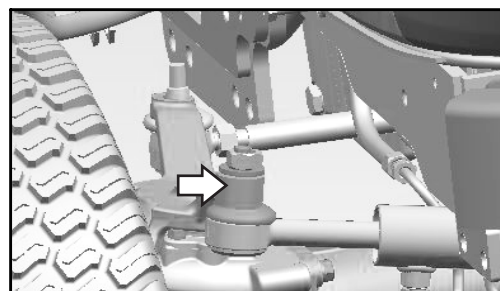

## 4WD Front Axle Oil Change

Oil filling plug is provided on right hand side of the front axle (as shown in fig.). Open the plug and check the oil level. The lower point of the plug should be immersed in the oil.

Recommended front axle oil & quantity is listed at the end of this chapter.

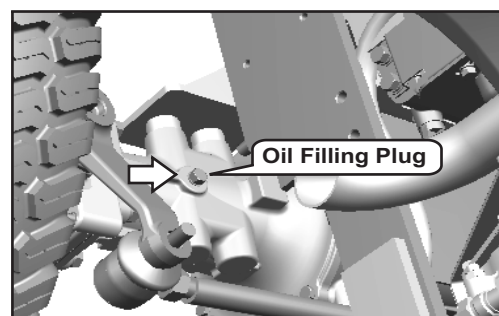

## Transmission and Hydraulic Oil Change

### Oil Drain

1. Lower the lift arms to the ground.
2. Unscrew the all plugs located as shown fig.
3. Place vessel under all drain plugs of transmission housing to collect the oil as it drains out.
4. Remove the plugs and drain out the oil.
5. Clean the drain plugs and re-fit.

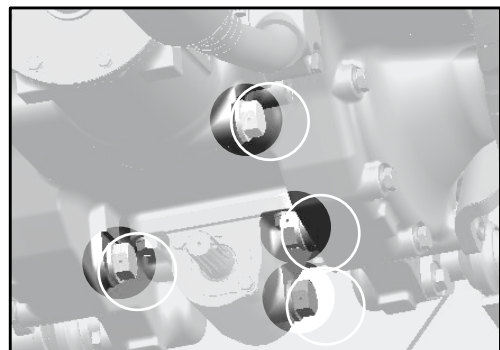

*Beware of powerful oil jets. Follow all safety rules.*

**NOTE:** When draining out and filling oil and checking oil level, take care that the transmission is in horizontal position.



# MAINTENANCE

## Transmission Oil Filling

Filling point located on rear side of the transmission.

1. Fill transmission oil from dipstick plug (1) opening to the maximum level mark on the dipstick.
2. Put the gearshift lever in neutral and start the engine. Let it run on idle until the oil reaches a temperature over 77 °F [25 °C].
3. Fully tighten the dipstick check that the transmission oil reaches the required level mark on the dipstick.
4. If required, fill up to the correct level.

**NOTE :** Let the oil stabilize before checking its level.

**IMPORTANT:** See the lubricants and fuel chart for the type of oil to be used according to the transmission type.

**NOTE :** If implement used requires more quantity of oil, make sure that the transmission contains enough oil for every work condition. Top off as required.

## Recommended Oil Grade-

We recommend use of **ISO VG-32** oil grade for transmission.

Refer below table for appropriate oil viscosity according to the ambient temperature.

Oil Grade	Ambient Temp. (°F)	Oil Temp.(°F)
VG 32	-50~80.6	37.4~158
VG 56	32~96.8	50~176

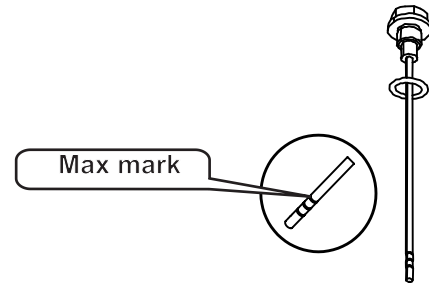
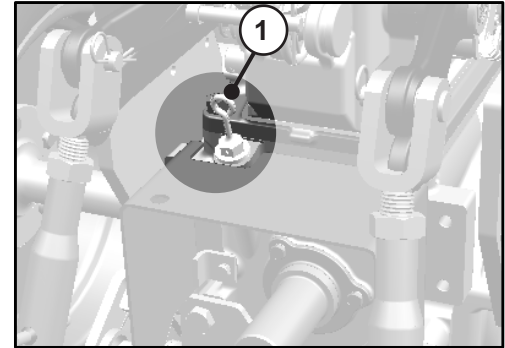

# MAINTENANCE

## Hydraulic Filter Replacement

Replace the hydraulic filters with genuine parts as per schedule to enhance the life and performance of hydraulic system.

**Replacement:** Replace the hydraulic filters (suction & delivery) at first 50 hours and afterwards at every 250 Hours.

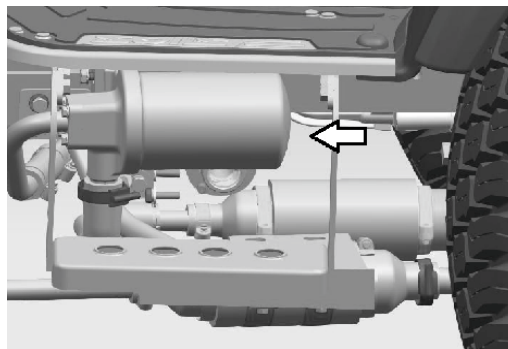

LHS (Suction Filter)

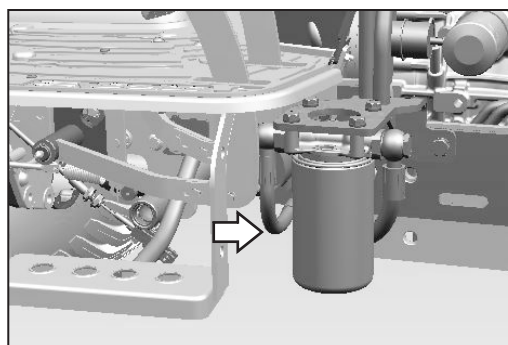

RHS (Delivery Filter)

# MAINTENANCE

## Hydraulic Suction Strainer

For HST transmission, double suction filters are used which are located left-hand side below the platform.

At each service, thoroughly clean suction strainer/strainers by washing with light oil

Failure to observe this will result in extensive shortening life of hydraulic system.

### Cleaning Procedure :

- (1) Remove all hose clamps (1).
- (2) Separate the hose pipes (2) from strainer assy.
- (3) Hold the strainer assembly in left hand & remove the wire clip (5) & magnetic strainer (4) from the housing (3) with the help of right hand fingers.
- (4) Unscrew the nut (6) & remove supporting cup (7). After dis-assembling supporting cup remove the sheath (8) having ferrous dust by sliding it with the help of plastic support (10).
- (5) Clean the sheath from ferrous dust with the help of soft cloth and refit the same.
- (6) Assemble the supporting cup & tighten the nut.
- (7) Assemble magnetic strainer in strainer housing and lock it with the wire clip.
- (8) Fix the hose pipes and tighten the hose clamps.

**Replacement:** Replace the magnetic strainer at every 750 Hours.

**IMPORTANT:** Do not dismantle the magnets (9) as these are assembled in polarity sequence and it should not be disturbed.

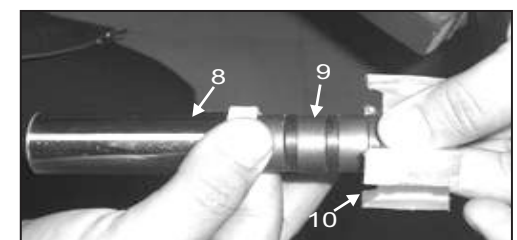
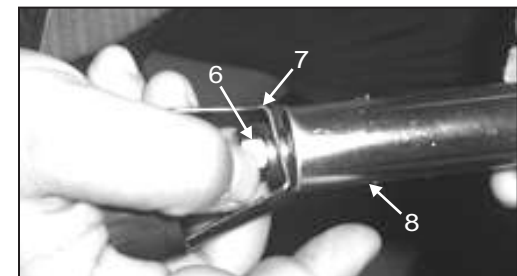
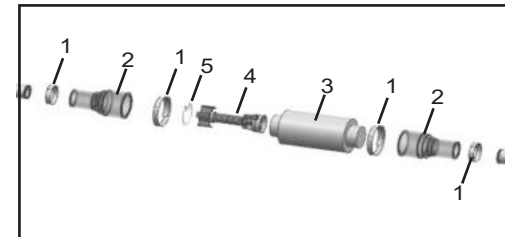
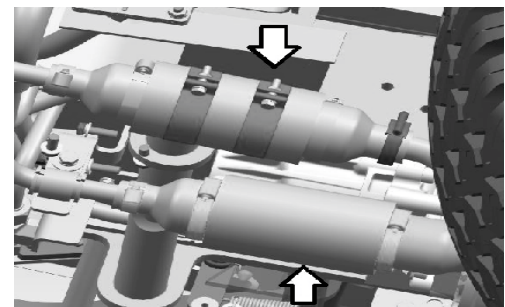
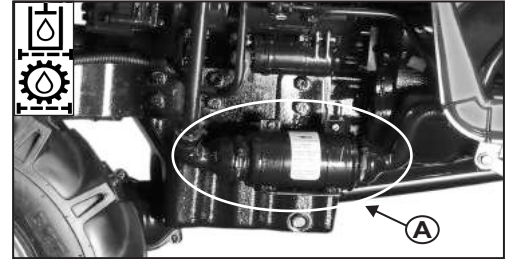

# MAINTENANCE

## General Maintenance of Electrical System

- Never patch up the electrical circuits.
- Never replace a blown fuse by a higher capacity fuse. It could cause a fire.
- Never work on components such as the alternator or starter motor when the engine is running.
- Lastly when you are cleaning the tractor and using the pressure spray, take care not to damage the connections on the various electrical cable.

## Battery and Maintenance

Battery Capacity: 12V, 65 Ah

### Battery Removal Procedure

Battery is located at front of the tractor as shown in the figure, follow the below procedure to access the battery:

1. Open the hood.
2. Remove fly nut by rotating it counter-clockwise.
3. Detach the negative (-) & positive(+) terminals.
4. Change battery having more than 700 CCA for cold weather operations beyond 14 deg F.

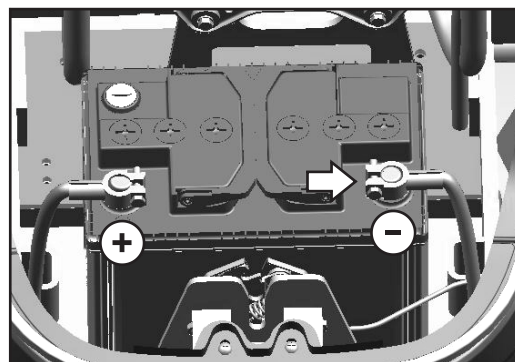

### Check Electrolyte Level

It must be as per the recommendation of battery manufacturer. If required, top up with distilled water just touching the 'Max' mark on the battery. Electrolyte level should never be below 'Min' mark. Never add acid.

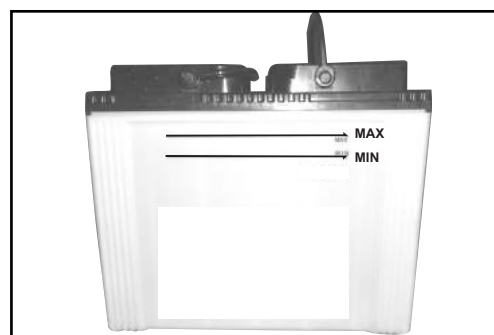

### Check Carefully Battery Charging

Protect against freezing. Insure that terminals are clean and tight. Check specific gravity of battery using a battery hydrometer. Specific gravity of a fully charged battery is  $1.265 \pm 0.005$  at  $80.6^\circ\text{F}$  [ $27^\circ\text{C}$ ].



*Battery posts, terminals, and related accessories contain lead and lead compounds, chemicals known to the state of California to cause cancer and reproductive harm. Wash hands after handling.*



*Remember to disconnect the cables before you recharge the battery. It is advisable to remove the battery from its location and to recharge it well away from the tractor. The place of battery recharge must be well ventilated.*

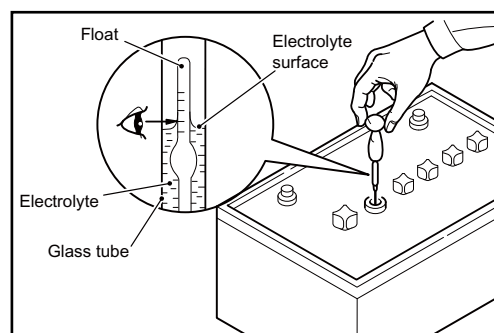

# MAINTENANCE

## Fuses in Fuse Box

Fuses against short circuits and excessive power draw protect the tractor's electrical system. The number of the fuses in the electrical system depends on the tractor model.

**NOTE :** Before replacing a blown fuse with a new, equivalent ohm, the cause that lead to the fault should be determined and removed.

## Long Storage Period

Take the following precautionary measures when your tractor is not going to be used for a long period of time.

- Park the tractor in dry sheltered place.
- Drain the coolant from the radiator and engine.
- Grease all points provided with grease nipples.
- Remove the injectors and squirt a small quantity of engine oil into the cylinders. Turn the engine over by hand, and then fit the injectors back in place.
- Generally clean the tractor particularly the bodywork components. Protect the painted parts by applying silicon wax and the unpainted metal parts by applying protective lubricant. Park the tractor in a dry, sheltered and possibly ventilated place.
- Make sure that all the controls are in neutral (including the electric switches and parking brake controls).
- Remove the ignition key from ignition switch.
- Make sure that the cylinder stems (of the power steering, power lift system, etc) are positioned.
- Empty the fuel tank and fill with it with new diesel fuel until the maximum level is reached.
- Remove the battery, clean the cover and spread vaseline on the terminal and terminal caps. Now connect the battery in the ventilated place where the temperature is not liable to drop below 10 and where it is not exposed to direct sunlight.
- Check the battery charge with a voltmeter as described in the battery part of this section recharge if it is necessary.
- Place stands or other supports under the axles in order to take the weight off the wheels. When the tractor is raised in this way, it is advisable to deflate the tires. If this is not possible, the tire pressure must be periodically checked.
- Cover the tractor with a tarpaulin.

86	30	10A	15A	15A	86	30
PTO SAFETY START RELAY	PARK LIGHT	LOW BEAM	HIGH BEAM	CRUISE-ON RELAY		
87	87A	10A	15A	87	87A	85
	ECG	BATTERY AUX	AUX.1			
86	30	30	86	30	86	30
OPC RELAY	PARK STOP RELAY	ENGINE STOP RELAY	CRUISE-OFF RELAY			
87	87A	85	87	87A	85	87A
	85	87	87A			
15A	5A	20A	15A	15A	15A	15A
PLOUGH LAMP	CRUISE MAGNET	COMB. SW.	MOBILE CHARGER	FLASHER		BRAKE LIGHT



At the end of the long storage period. When you start the engine again, pay particular attention to the instruction about starting engine in the operation chapter.

# MAINTENANCE

## Starter Motor

Starter motor is mounted on the left side of the engine. The starting motor rotates the engine crankshaft for starting.

Visually check the starter for damage. If starter is dusty, blow off dust using compressed air.

Note: If defects are found in the starter, contact your servicing dealer.

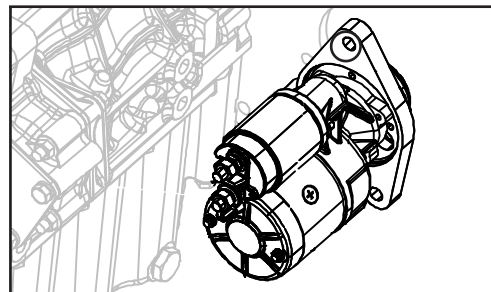

## Alternator

Alternator is fitted on left side of engine and generates current which charges battery for healthy electrical back up.

Visually check the alternator for damage. If the alternator is dusty, blow off dust using compressed air.

Remove V-belt, and turn the pulley with hands to make sure it rotates smoothly.

Note: If defects are found in the alternator, contact your servicing dealer.

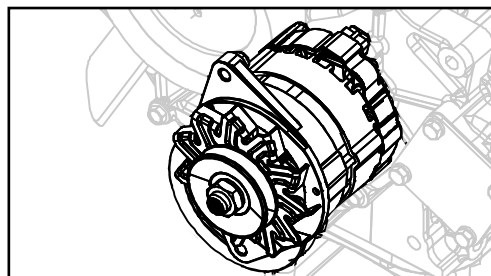

## Checking V-belt:

1. Ensure that V-Belt is free from defects such as wear, cuts or surface separations, otherwise replace with genuine specified belt.
2. Inspect belt tension by pushing the belt downward with approx. 22lbf (98N) (10kgf) force midway between pulleys. If the deflection is 0.39 to 0.47 Inch [10 to 12mm], the tension is correct. If the tension out of the specified value, adjust belt tension.

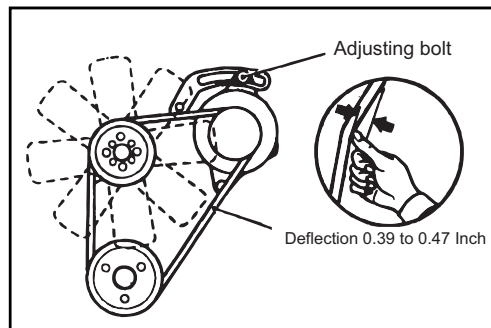

## Adjusting V-belt tension:

1. Lose all retaining bolts of the alternator and adjusting plate.
2. Insert a bar between the alternator and cylinder block and use leverage to move that alternator to have proper v-belt tension.
3. While V-belt tension is appropriate, retighten all the retaining bolts of the alternator and adjusting plate.

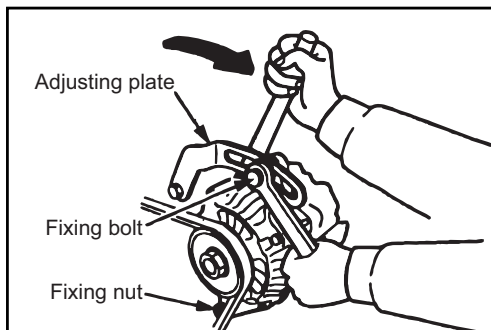



# MAINTENANCE

## Greasing Points

- |   |            |
|---|------------|
| 1. Brake pedal                          | - 1 Point  |
| 2. Power Steering Cylinder Mounting Min | - 1 Point  |
| 3. Front Axle Pivot Pin                 | - 1 Point  |
| 4. Drag Link (LH and RH)                | - 2 Points |
| 5. Top Link                             | - 2 Points |

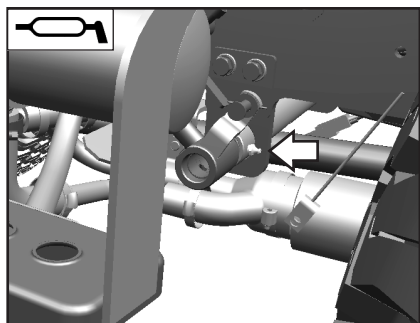

1. Brake Pedal

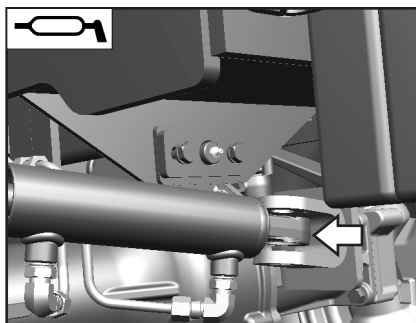

2. Power Steering Cylinder  
Mounting Min

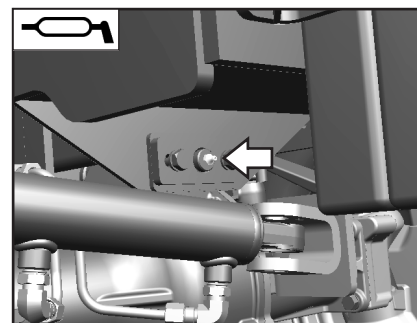

3. Front Axle Pivot Pin

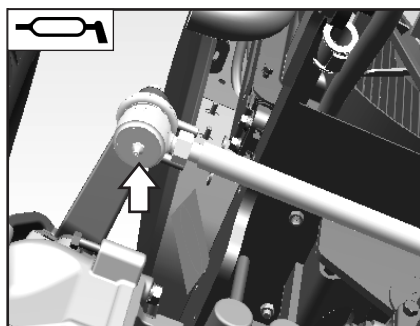

4. Drag Link

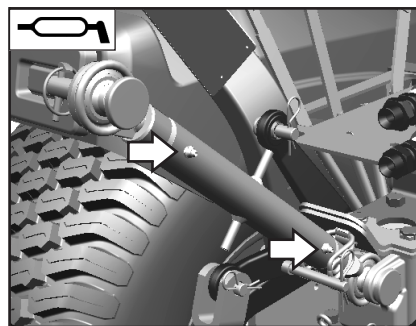

5. Top Link



# MAINTENANCE

## Jack Up the Tractor - Lifting Points

The illustrations show the recommended lifting points for jacking up the tractor. Use a stable lifting jack with sufficient lifting force.

- A- Raise right end of axle, e.g. to remove right front wheel.
- B- Raise center of axle (Use wooden wedges to prevent axle from tilting).
- C- Raise left end of axle, e.g. to remove left front wheel.
- D - Raise rear of tractor, e.g. to remove rear wheel



CAUTION

- Use approved lifting equipment only.
- Jack up tractor on firm, level ground only.
- Before doing any further work on the tractor, first secure it using suitable support stands.

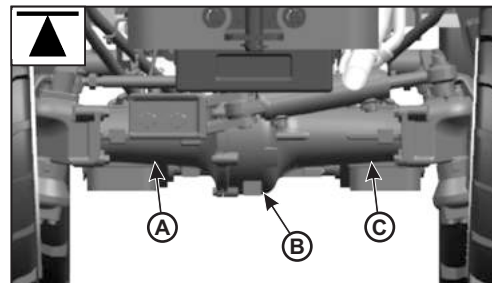

Raise front of tractor

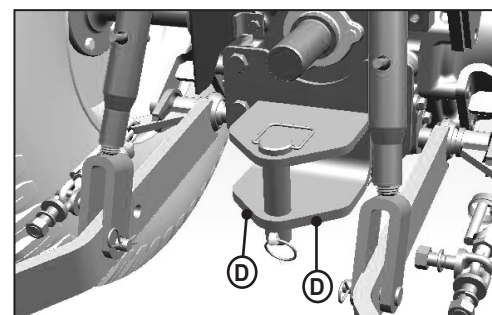

Raise rear of tractor

## Oil and Lubrication Chart

Aggregate	Capacity	Recommended Grade
<b>Engine Oil</b>	1.11 US Gallons [4.2 Liters]	15W40, API: CJ-4, CI-4 Plus, CI-4, CH-4 Total Rubia TIR 7900 : 0W40, CI-4 or higher for temp beyond 14 deg F to -4 deg F (-10 deg C to -20 deg C)
<b>Transmission</b>	6.604 US Gallons [25 Liters]	ISO VG 32/ISO VG56
<b>Front Axle</b>	0.71 US Gallons [2.7 Liters]	Total Dynatrans MP / API: GL-5
<b>Fuel</b>	6.87 US Gallons [26 Liters]	Ultra low sulfur diesel
<b>Coolant</b>	1.14 Gallons(4.3L) {0.45 Gallons (1.72L)Antifreeze & rest DM Water} Recommended ratio: 40% : 60% (Antifreeze : Distilled mineral water)}	

## TECHNICAL SPECIFICATIONS

Model		SUMMIT TX25
Engine	Make	Mitsubishi
	Engine Type	Natural Aspiration
	Gross Engine Power HP(Kw)	24.7(18.4 kw)
	PTO HP (kw)	18(13.4)
	Displacement cu.in.(cc)	80.42(1318)
	Rated Engine Speed	2500
	Number of Cylinders	3
	Cooling System	Liquid
	Air Cleaner	Dual Element
	Alternator	12V42A
	Starting Aid	Glow Plug
	Fuel System Type	Indirect Fuel Injection
	Fuel Tank Capacity U.S.gal(L)	6.9(26)
	Powertrain	Transmission type
Forward/Reverse Foot Control		Twin Touch Pedals
Cruise Control		Standard
Max. Traveling Speed mph(km/h)		11.32(18.22)
Brakes		Wet Disc
Steering		Hydraulic
Hydraulic	Pump Type	Open Center
	Hydraulic Flow. gpm(L/Min)	4.8(18)
	Category 3 Point Hitch	1
	3 PT Hitch Lift Capacity.lb(kg)	1322(600)
	At 24 Inches Behind Link Ends.lb(kg)	1168(530)
	Lift Control Type	Position Control

## TECHNICAL SPECIFICATIONS

### Overall Dimensions-

Description	Goodyear R14 23x8.50-12	Front - 6.5-80-12	Front- 23 x 8.50-12 (Industrial)	Front - 25x8.50-14 (Turf)	Front - 220/55R12	Front- 23x8.5-12
	Goodyear R14 12-16.5	Rear- 280/70 R18	Rear- 33x15.5-16.5 (Industrial)	Rear- 13.6X16 (Turf)	Rear - 280/70R16	Rear- 33X15.5-16.5
Overall Length, Inch(mm)	113.98 (2895)	113.98(2895)	113.98(2895)	113.98(2895)	113.98(2895)	113.98(2895)
Overall Width, Inch(mm)	54 (1371)	50.79(1290)	61.02(1550)	56.30(1430)	51.38(1305)	61.02(1550)
Overall Height, Inch( mm)	91 (2311)	92.52(2350)	91.14(2315)	94.10(2390)	90.95(2310)	90.95(2310)
Wheel base, Inch(mm)	61.81 (1570)	61.81(1570)	61.81(1570)	61.81(1570)	61.81(1570)	61.81(1570)
Front Axle Track Width (Standard), Inch(mm)	37.91(963)	35.83(910)	37.20(945)	39.37(1000)	37(940)	37(940)
Rear Axle Track Width (Standard), Inch(mm)	40.63(1032)	39.37(1000)	45.28(1150)	40.95(1040)	39.37(1000)	45.47(1155)
Minimum Ground Clearance, Inch(mm)	9.45 (240)	8.46(215)	9.06(230)	10.24(260)	8.27(210)	9.06(230)
Weight Pounds(Kg)	2557 (1159)	2557.36(1160)	2700.66(1225)	2623.50(1190)	2557.36(1160)	2755.78(1205)

**Note:** All dimensions & specifications are for guidance purpose only & are subjected to change without prior notice.

# DO'S AND DON'TS

## 7. Do's and Don'ts

### DO'S

#### ENGINE

##### a. General

1. Do release the starter key once the engine has started.
2. Do check the proper functioning of oil pressure gauge and battery charging indicator once the engine has started.
3. Do get the tightness of cylinder head and manifold nuts checked regularly.

##### b. Air inlet System

1. Do inspect the element pre-cleaner / oil bath. Clean if necessary.

##### c. Fuel System

1. Do drain sediments from the fuel tank periodically
2. Do clean fuel tank thoroughly once in every 500 hrs.
3. Do change filter regularly as recommended in service schedule.
4. Do fill diesel in the tank at the end of the day's work so as to avoid condensation.

##### d. Water cooling System

1. Do ensure that radiator is always filled with clean (soft) water & radiator cap is tight
2. Do clean the radiator front grill to ensure free flow of air when the engine is operating.
3. Do ensure proper tension of fan belt. Deflection should not be more than 0.39 Inch when pressure is applied between the fan pulley and the crankshaft pulley.

##### e. Lubrication System

1. Do replace engine oil after first 50hrs. of operation. Thereafter, engine oil should be replaced every 250 working hrs.
2. Do check oil level daily with tractor parked on a level ground.
3. Do replace lub. oil filter element every 250 working hrs. After 1st replacement at 50 hrs.

##### f. Exhaust System

1. Do ensure that the exhaust passage is not blocked.

#### CLUTCH

1. Do ensure correct clutch free pedal play
2. Do ensure that the clutch pedal is released slowly while moving the tractor.

### DON'TS

#### ENGINE

##### a. General

1. Do not keep on continuously cranking the engine with starter key. It will shorten the life of battery.
2. Do not race the engine in neutral condition.

##### b. Air inlet System

1. Do not run the tractor if the air cleaner assembly is defective as this will lead to impure air being taken in and consequently excessive wear of liners and piston rings.

##### c. Fuel System

1. Do not keep the fuel tank without a proper sealing cap.
2. Do not use contaminated fuel as it may affect the operation of fuel injection pump and the injectors.
3. Do not allow leakage through fuel pipe joints.

##### d. Water Cooling System

1. Do not run the tractor with the radiator cap removed/non-acting radiator cap.
2. Do not run the tractor when the radiator hoses are leaking as it will lead to overt heating of the engine.
3. Do not remove thermostat as it will affect engine performance.
4. Do not run the belt tight as it will lead to premature failure of water pump and alternator bearing.
5. Do not run the belt loose as it will lead to inefficient cooling and improper charging of the battery.

##### e. Lubrication System

1. Do not use wrong grade of lubrication oil.
2. Do not mix different brands of engine oil.

#### CLUTCH

1. Do not rest the foot on the clutch pedal.
2. Do not work the tractor by slipping and re-engaging the clutch.
3. Do not coast down steep slopes with tractor in neutral/with clutch pedal pressed.

# DO'S AND DON'TS

## DO'S

### TRANSMISSION

1. Do change the transmission oil after 1000 hrs. of operation.
2. Do check the condition of rubber protection bellows on the gear levers periodically as they prevent infiltration of water and dust into gear box.

### HYDRAULIC SYSTEM & LINKAGE

1. Do ensure that hydraulic control lever is in down position while draining the transmission oil.
2. Do ensure that the hydraulic strainer is cleaned at every schedule.
3. Do adjust the top link for proper length.
4. Do ensure that the lift cover bolts are always tight.
5. Do keep the lower links in lifted position when the tractor is moving without an implement mounted on it.
6. Do keep the ball joints on top and lower links clean and dry. Do not lubricate them.
7. Do ensure that implements are raised and lowered using the control lever.

### BRAKING SYSTEM

1. Do keep the brake pedals locked with interlocking latch when the tractor is not being used in field.
2. Do use parking brakes when the vehicle is stationary
3. Do check loose connections in linkage mechanism
4. Do grease brake pedal bushing, brake bracket connections.

### FRONT AXLE & STEERING MECHANISM

1. Do lubricate the bushings and steering drag links periodically.
2. Do get the toe-in adjusted by an authorised service center periodically. It should be maintained between 0.12-0.24 inch
3. Do check the tightness of front and rear wheels to recommended torque
4. Do flush oil once a year or 1000 hrs which ever is earlier.

### TIRES

1. Do operate the tractor with correct tire pressure. This will lead to better traction, longer tire life and better fuel consumption.

## DONT'S

### TRANSMISSION

1. Do not use top gears with low engine rpm.

### HYDRAULIC SYSTEM & LINKAGE

1. Do not move the operational control range to fast response, while the tractor is on a hard surface like concrete, as the implement will crash down and get damaged.
2. Do not attempt to pull or tow anything from the top link connection. It is dangerous.
3. Do not use bolts in place of lynch pins.
4. Do not reverse the tractor with PTO driven implement attached and PTO lever in ground PTO position implement may get damaged in reverse.

### BRAKING SYSTEM

1. Do not attempt to turn sharply using independent brakes when travelling at high speed. This may cause the tractor to overturn.
2. Do not rest foot on the brake pedal.

### FRONT AXLE & STEERING MECHANISM

1. Do not use wrong grade of oil for lubrication of steering gear box.

### TIRES

1. Do not allow oil, grease and some crop spray containing considerable amounts of acid and alkalies to contaminate the tires. These can cause considerable damage to the tyre if they penetrate into plies through small holes or splits.
2. Do not operate the tractor with excessive tire pressure.

# DO'S AND DON'TS

## DO'S

### ELECTRICALS

1. Do ensure that the battery terminals are kept clean.
2. Do ensure terminal base is lubricated with petroleum jelly.
3. Do earth the tractor by wrapping a chain around the front axle, dropping one end of the chain on the ground while working with stationary PTO driven implement. This saves the electric equipment from damage due to static electricity.
4. Do clean the switches periodically using a jet of air.

### SAVE DIESEL

- Do switch off the engine when tractor is not in operation. Avoid unnecessary idling.
- Do operate at optimum speed and correct gear.
- Do maintain the recommended tire pressure for fuel efficient operation and long life of tires. Check daily.
- Do use matching trailer for transportation. Ensure proper hitching. Never overload the trailer.
- Do maintain your tractor in good working condition.
- Do replace genuine parts from Summit authorized servicing dealer.

### For Better performance

- Ensure that safety shields are in place and in good condition.
- Read all operating instructions before commencing to operate tractor.
- Keep the air cleaner clean.
- Fit new sealing rings when the filter elements are changed.
- Watch the oil pressure gauge or warning light and investigate any abnormality immediately.
- Ensure that the transmission is in neutral before starting the engine.
- Keep all fuel in clean storage container and use a filter when filling the tank.
- Attend to minor adjustments and repairs as soon as there is a need.
- Allow the engine to cool before removing the radiator filler cap and adding water, remove the radiator cap slowly.
- Shift into low gear when driving down steep hills.
- Latch the brake pedals together when driving on a highway.

Ensure daily care of your tractor to avoid breakdowns.

## DONT'S

### ELECTRICALS

1. Do not change leads of the battery terminals as this will lead to failure of electrical components.
2. Do not leave the battery leads in the connected position if the tractor is not going to be used for a long period of time.
3. Do not overfill the battery with distilled water. The level should be just enough to submerge the battery plates.
4. Do not do any welding in the tractor without disconnecting battery terminals.

### EVERY DROP COUNTS

- Do not allow fuel or oil to leak. Ensure that the joints are adequately tight.
- Do not spill fuel or oil while filling or topping off. Use a funnel.
- Do not overfill engine oil as this can cause excessive oil consumption and oil leaks.
- Do not ride the clutch or brake pedal.
- Do not allow the rear wheel to slip. Use ballast, if necessary.
- Do not use worn-out tires.
- Do not use inferior quality lubricants, use only recommended grade.

### For safe operation

- Do not run the engine with the air cleaner disconnected.
- Do not start the tractor in an enclosed building unless the doors and windows are open for proper ventilation.
- Do not operate the tractor or engine while lubricating or cleaning.
- Do not tamper with the fuel injection pump, (if the seal is broken) the warranty becomes void.
- Do not allow the engine to idle for a long period of time.
- Do not use the independent brakes for making turns on the highway or at high speeds.
- Do not refuel the tractor with the engine running.
- Do not start the engine with the PTO engaged.

Carefully read and follow the other instructions given in the Do's and DON'Ts maintenance booklet, to ensure maximum saving of oil/fuel.



# TROUBLESHOOTING

PROBLEM	POSSIBLE CAUSE	REMEDY
<b>ENGINE</b>		
<b>Engine not starting</b>	Wrong way of starting engine	Use proper way of starting
	No fuel	Check Fuel level
	Air trapped in fuel system	Bleed the fuel system
	Checking of fuel syst	Contact authorized servicing dealer
	Fuel injector faulty	Replace fuel injector
	Pull to lever knob in pulling condition	Return to its proper position
	Fuel filter restriction	Replace fuel filter
<b>Engine not running smoothly</b>	Fuel filter restriction	Replace fuel filter
	Low quality of fuel	Drain diesel from fuel tank and fill with clean diesel.
	Restriction of fuel system	Check fuel system
	Fuel injector faulty	Replace fuel injector
<b>Excessive oil consumption</b>	Oil level is more than maximum level	Remove some oil to lower the level
	Oil leakage	Check and repair
<b>Engine not giving maximum power</b>	Oil quality is not good	Use genuine oil
	Heavy load on engine	Adjust load or implement setting
	Air cleaner dirty	Clean air cleaner
	Fuel filter restriction	Replace filter
	Engine overheating	Check cooling system
	Engine operating temperature is less	Check thermostat
	Valve clearance not proper	Adjust through authorized servicing dealer
	Throttle system not working properly	Check & repair through authorized servicing dealer
<b>Engine abnormal noise</b>	Oil level low	Top up oil up to level
	Oil pressure low	Check through authorized servicing dealer
	Engine is overheated	Check and find reason
	Improper tappet setting	Contact to authorized servicing dealer
<b>Oil pressure indicator show warning</b>	Oil level low	Top up oil up to level
	Oil quality is not good	Use genuine engine oil
	Oil pump not working	Check and repair through
<b>Engine over heating</b>	Radiator cap faulty	Replace with new one
	Clogged radiator fins	Clean it
	Engine gets overload	Decrease load or shift to low gear
	Oil level is low	Top up oil up to level
	Coolant level is low	Check level and leakage of system and top up
	Slippage of fan belt	Check belt tension
	Thermostat faulty	Replace
	Choking of cooling system	Clean the cooling system
	Water temp. gauge not working	Check through servicing dealer and faulty replace



# TROUBLESHOOTING

PROBLEM	POSSIBLE CAUSE	REMEDY
<b>ENGINE</b>		
<b>Excessive fuel consumption</b>	Air cleaner is dirty / clogged	Clean air cleaner
	Overloading of engine	Reduce load or shift to low gear
	Improper valve clearance	Check and adjust
	Implement setting improper	Contact servicing dealer for how to adjust it correctly
	Low engine temp	Check injectors and service
	Fuel injection nozzle faulty	Check and service through authorized servicing dealer
<b>HYDRAULIC</b>		
<b>Excessive heating of oil</b>	Incorrect hydraulic pressure	Adjust relief valve according to specification
	Oil level is high or less	Check and maintain proper level
	Hydraulic strainer clogged	Clean or replace
<b>Linkage goes down slowly</b>	Mechanical linkage might be faulty	Contact your authorized servicing dealer
	Bush tight	Contact your authorized servicing dealer
	Response valve setting improper	Contact your authorized servicing dealer
<b>Linkage not lift fully</b>	Improper lift arm setting	Contact your authorized servicing dealer
	Improper internal adjustment	Contact your authorized servicing dealer
<b>TPL not respond to lifting while operating hydraulic lever</b>	Linkage not connected properly	Contact your authorized servicing dealer
	Heavy load on linkage	Contact your authorized servicing dealer
<b>Hydraulic system not working properly</b>	Response valve setting very low	Contact your authorized servicing dealer
	Oil level low	Check and top up
	Hydraulic strainer clogged	Clean or replace
	Hydraulic system faulty	Contact your authorized servicing dealer
	Hydraulic pump not working	Contact your authorized servicing dealer
<b>BRAKES</b>		
<b>Noise while applying brakes in one side</b>	Wrong adjustment of brake pedal	Check and adjust
	Brakes only work when fully pressed	Check and adjust
<b>Brakes only works when fully pressed</b>	Wrong adjustment of brakes	Check and adjust
<b>ELECTRICAL</b>		
<b>Electrical system not working</b>	Battery terminal loose or rusting of terminal	Clean and tighten the terminals
	Less specific gravity	Replace or fill electrolyte up to level
<b>Startet motor not working</b>	Battery terminal loose / Battery discharged	Tighten / Recharge or replace battery
	Faulty starter motor	For repair contact your authorized servicing dealer
<b>Battery not charging</b>	Loose or rusted terminals	Clean and tighten terminal
	Belt loose	Check belt tension
	Faulty battery	Replace

\* TPL = Three Point Linkage



# ALPHABETICAL INDEX

<b>Number</b>	
2WD / 4WD <sup>1</sup> Lever.....	40-5
<b>A</b>	
Adjusting V-belt tension.....	50-14
Air Bleeding of Fuel System.....	50-4
Air Cleaner Clogging Indicator.....	30-3
Air Cleaner Maintenance.....	50-7
Alphabetical Index.....	80-4
Alternator.....	50-14
<b>B</b>	
Battery.....	30-13
Battery and its Maintenance.....	50-13
Battery Charge Indicator.....	30-3
Boarding the Tractor.....	40-1
Breaking in.....	40-3
<b>C</b>	
Chassis Serial Number.....	10-8
Check Wheel Nut Bolt, Tread Settings.....	40-15
Checking Coolant Level in Radiator.....	50-4
Checking Engine Oil Level.....	50-5
Checking V-belt.....	50-14
Cleaning of Suction Strainer.....	50-11
Cold Start Indication.....	30-4
Cruise Control.....	30-7
Cruise Control.....	40-5
Cruise Control Switch.....	30-10
<b>B</b>	
Dashboard Controls.....	30-8
Differential Lock.....	40-6
Do's & Don'ts.....	70-1-3
<b>E</b>	
Engine.....	40-1
Engine Oil Pressure Indicator.....	30-5
Engine RPM Meter and Hour Meter.....	30-6
Engine Serial Number.....	10-8
<b>F</b>	
Foot Brake Pedals.....	50-8
Fuel Gauge.....	30-7
Fuel Tank Filling.....	50-3
Fuse Box.....	30-10
Fuses in Fuse Box.....	50-13
<b>G</b>	
Gear Speed Chart.....	40-12
General Maintenance of Electrical System.....	50-12
Greasing Points.....	50-15
Guidelines about Safety Sign.....	20-5
<b>H</b>	
Hand Throttle Lever.....	40-6
High Beam Indicator.....	30-4
Hi-Low Lever.....	40-11
Hydraulic Coupling Devices.....	40-10
Hydraulic Filter Replacement.....	50-10
<b>I</b>	
Inspection of Hoses.....	50-6
Instrument Panel.....	30-2
<b>J</b>	
Jack Up the Tractor-Lifting Points.....	50-16
<b>L</b>	
Leaving the Tractor.....	40-1
Left Turn Indicator.....	30-3
Long Storage Period.....	50-13
<b>M</b>	
Maintenance Schedule.....	50-1
<b>N</b>	
Noise & Vibration Levels.....	20-26
<b>O</b>	
Oil and Lubrication Chart.....	50-16
Oil Changes in 4WD Front Axle.....	50-8
Opening and closing the Hood.....	40-4
Operator Presence Control (OPC).....	40-1
Operator's Seat.....	30-12
<b>P</b>	
Parking Brake.....	40-11
Parking Brake Indicator.....	30-3
Power Steering.....	40-10
PTO.....	40-7
PTO Monitor Lamp.....	30-6
PTO On/Off Switch.....	30-10
PTO ON-OFF Switch.....	40-6
<b>R</b>	
Radiator.....	50-4
Radiator Cap.....	50-6
Radiator Draining & Flushing.....	50-6
Radiator Fins Cleaning.....	50-6
Replacement of Fuel Filter.....	50-4
Replacement of Oil Filter & Engine Oil.....	50-5
Right Turn Indicator.....	30-4
Roll Over Protection Structure (ROPS).....	40-19
ROPS Certificate Plate.....	10-8
<b>S</b>	
Safety From Lightning Strike.....	20-25
Safety Labels.....	20-5
Safety Labels Location.....	20-6-10
Safety Notes.....	20-12-25
Safety While Operating Loader Attachments.....	20-24
Safety: Prepare For Safe Operation.....	20-11
Service Brakes.....	40-11
Service Record.....	80-3
Seven Pin Socket.....	30-13
Speed Control Pedal.....	40-4
Starter Motor.....	50-14
Starting the Engine.....	40-1
Statutory Plate.....	10-8
Steering Cylinder Knuckle Joints.....	50-8
<b>T</b>	
Technical Specifications.....	60-1
Temperature Gauge.....	30-5
Three Point Linkage.....	40-17
Tractor Controls.....	30-1
Tractor Lights.....	30-11
Trailer Turn Indicator.....	30-6
Transmission and Hydraulic Oil Change.....	50-8
Transmission Oil grades.....	50-9
Transport Lock (Response Valve).....	40-10
Troubleshooting.....	80-1-2
Turning off the Engine.....	40-3
<b>U</b>	
Under Hood Muffler.....	40-4
Universal Symbols.....	10-9
Using Operator Manual.....	10-7
<b>W</b>	
Warranty Guidelines.....	20-1-4
Wheels and Tires.....	40-12
Work Lamp Indicator.....	30-7

The logo for Summit Tractors features the word "SUMMIT" in a bold, dark green, sans-serif font. A thin, dark green arc curves over the top of the letters. Below "SUMMIT" is the word "TRACTORS" in a smaller, dark green, sans-serif font, flanked by two horizontal lines. The entire logo is centered on a light gray background.

**SUMMIT**<sup>™</sup>  
— TRACTORS —